

# OPERATING INSTRUCTIONS

GA02412\_0202



## ScrewLine SP 250

Dry Compressing Vacuum Pump

### P/N

115 001  
115 002  
115 003  
115 004  
115 005

 **Leybold**  
vacuum

Section	Page
<b>Important Safety Information</b> .....	<b>6</b>
<b>1 Description</b> .....	<b>9</b>
1.1 Area of Application .....	9
1.2 Principle .....	10
1.2.1 Design .....	10
1.2.2 Principle of Operation .....	12
1.3 Technical Data .....	13
1.3.1 Available Documentation .....	15
1.4 Supplied Equipment .....	15
1.5 Pump Versions .....	16
1.6 Accessories .....	16
1.7 Spare Parts .....	16
1.8 Storing .....	16
<b>2 Operation</b> .....	<b>17</b>
2.1 Placement .....	17
2.1.1 Transport .....	17
2.1.2 Floor .....	18
2.1.3 Air Cooling and Pump Covers .....	18
2.1.4 Ambient Conditions .....	19
2.1.5 Installation Location .....	19
2.2 Connection to the System .....	20
2.2.1 Connections at the Intake Side .....	20
2.2.2 Connections at the Delivery Side (Exhaust) .....	21
2.3 Electrical Connection .....	22
2.3.1 Motor Protection .....	23
2.3.2 Star/Delta Start-up Circuit .....	24
2.3.3 Soft Start .....	24
2.3.4 Mains Connection .....	25
2.3.5 Power Failure .....	27
2.4 Commissioning .....	28
2.4.1 Oil Filling for the Gear .....	28
2.4.2 Switching the Pump On .....	30
2.4.3 Oil Temperature .....	31
2.4.4 Regular Checks .....	31
2.5 Operating Conditions .....	32
2.6 Switching Off/Shutting Down .....	33
2.7 Emergency Shutdown .....	33

<b>Section</b>	<b>Page</b>
2.8	Pump Monitoring . . . . . 34
2.8.1	Oil Temperature Sensor Pt 100 . . . . . 34
2.9	Operation with Gas Ballast . . . . . 35
2.9.1	Manually Operated Gas Ballast Valve . . . . . 35
2.9.2	Solenoid Gas Ballast Valve . . . . . 37
<b>3</b>	<b>Maintenance . . . . . 39</b>
3.1	Checking the Oil Level . . . . . 40
3.1.1	Oil Change and Oil Filter Change . . . . . 40
3.2	Cleaning the Oil Cooler . . . . . 42
3.3	Draining Out Condensate (optional). . . . . 43
3.4	Cleaning the Dust Filter (optional) . . . . . 43
3.5	Leybold Service. . . . . 44
3.6	Table/Maintenance and Servicing Work ScrewLine 250 . . . . . 45
<b>4</b>	<b>Troubleshooting . . . . . 46</b>
	<b>EC Declaration of Conformity. . . . . 47</b>

These Operating Instructions apply to standard products only. If the pumps which have been delivered are of a custom design, then the delivery will include additional instructions which are part of the Operating Instructions.

**Warning**



## Notes



### Warning

We strongly recommend that you read these Operating Instructions with care so as to ensure optimum operation of the pump right from the start.



The icon indicates procedures that must be strictly observed to prevent hazards to persons.

### Warning



This special icon warns about dangers caused by high electric voltages. Touching parts at a high voltage can result in immediate death.

Covers which are marked with this icon must only be removed by trained electricians after having reliably disconnected the electric power source.

### Caution

Indicates procedures that must strictly be observed to prevent damage to, or destruction of the equipment.

### Note

Emphasises additional application information and other useful information provided within these Operating Instructions.

**Leybold Service**

If a pump is returned to Leybold indicate whether the pump is free of substances damaging to health or whether it is contaminated.

If it is contaminated also indicate the nature of the hazard. Leybold must return any pumps without a "Declaration of Contamination" to the sender's address.

A copy of this form is reproduced at the end of these Operating Instructions: "Declaration of Contamination of Compressors, Vacuum Pumps and Components". Moreover, you may download a suitable form from the Internet: [www.leybold.com](http://www.leybold.com) under the headline "Support and Downloads".

**Disposal of Waste Oil**

Owners of waste oil are entirely self-responsible for proper disposal of this waste.

Waste oil from vacuum pumps must not be mixed with other substances or materials.

Waste oil from vacuum pumps (Leybold oils which are based on mineral oils) which are subject to normal wear and which are contaminated due to the influence of oxygen in the air, high temperatures or mechanical wear must be disposed of through the locally available waste oil disposal system.

Waste oil from vacuum pumps which is contaminated with other substances must be marked and stored in such a way that the type of contamination is apparent. This waste must be disposed of as special waste.

European, national and regional regulations concerning waste disposal need to be observed. Waste must only be transported and disposed of by an approved waste disposal vendor.

The references to diagrams, e.g. (1/2) consist of the Fig. No. and the Item No. in that order.

**Figures**

We reserve the right to modify the design and the specified data. The illustrations are not binding.

# Important Safety Information

The ScrewLine SP250 (termed ScrewLine in the following) must only be operated in the proper state and in the state described in the Operating Instructions. The dry compressing ScrewLine vacuum pump from Leybold will ensure, when used properly and in line with the information provided in these Operating Instructions, a safe and proper service. Please take some time to read all safety notes given in this chapter and the other chapters of these Operating Instructions, and make sure that these are complied with. The vacuum pump must only be operated, and any maintenance must be done only by trained staff. Please also note any special requirements and regulations which may apply at your location or which are demanded by law. In case you have any questions relating to safety, operation and/or maintenance of the vacuum pump please contact your nearest Leybold Vacuum sales office.

**Warning**  
**Non-compliance with the following precautions can result in severe injury.**



- Never operate the ScrewLine pump with an opened pump chamber or fan housing. There is the risk of suffering injury.
- The standard ScrewLine pump is not suited for pumping of:
  - combustible or explosive gases and vapours
  - radioactive and toxic substances
  - gas mixtures with an oxygen share of > 21%
  - pyrophorous substances

When planning such an application please contact us first.

- The standard ScrewLine pump is not suited for operation in explosion hazard areas.

When planning such an application please contact us first.

- Before operating the ScrewLine with gas ballast (optional), compatibility of the ballast gas with the media being pumped must be checked first, so as to avoid dangerous conditions.
- Before starting the ScrewLine up, check the substances which are to be pumped for compatibility so as to avoid dangerous conditions.

All relevant safety standards and regulations must be observed.

- In the exhaust line no pressure + 200 mbar/- 50 mbar with reference to atmospheric pressure may be allowed to build up ( $p_{ex} = p_{amb} + 200 \text{ mbar/- } 50 \text{ mbar}$ ), also not in those cases where the pumped out gases need to be collected or contained.
- Make sure that the gas flow at the exhaust is not blocked or restricted in any way.
- The electric motor must be protected by suitable means against being overloaded. For this note the information given in these Operating Instructions.

- The ScrewLine must be integrated within the system controller such that the pump can not run up automatically when the pump has been shut down before due to an overloaded motor.  
This equally applies to any emergency shutdowns. After having removed the fault cause, the pump must be switched on manually again.
- The location for the ScrewLine (including accessories) should, as a rule, be such that angles exceeding 10 degrees from the vertical are avoided. When tilting the ScrewLine by more than 10 degrees from the vertical, there is the risk that the pump may topple over.
- Avoid exposing any part of the human body to the vacuum.
- Never operate the ScrewLine without having connected the intake line or fitted a blank flange first.
- The noise level produced by the ScrewLine is given in the Chapter "Technical Data". Suitable hearing protection measures must be introduced.
- Before starting with any maintenance or servicing work reliably disconnect the ScrewLine from all sources of power.
- Before starting with any maintenance or servicing work make sure that no gas can flow backwards through the ScrewLine, since this might cause the rotors to turn. For this reason always vent the vacuum chamber to exhaust pressure or ensure, by installing suitable valves, that the vacuum chamber and the lines will be separated reliably from the pump.
- Select the location where the ScrewLine is installed so that all controls can be easily accessed.
- It is recommended always to operate the ScrewLine with a connected and suitable exhaust line.
- For transporting the ScrewLine use only approved means of transport.  
Two crane eyes are provided on the pump as standard.
- The pump, when filled with oil, may be installed with a maximum deviation of 2° from the vertical as otherwise oil may enter into the sealing system. Before filling the pump with oil, the pump must be aligned. Moving the pump while filled with oil is not permissible.
- Make sure that no small parts (bolts, nuts, washers, pieces of wire etc.) enter into the pump. For this reason always fit the inlet screen provided with each pump.
- When connecting the pump to a vacuum chamber, a suitable valve (electric isolating valve, for example) needs to be provided for interrupting the intake line so as to prevent the pump from running backwards in the event of a power failure. Otherwise the pump may suffer damage or the pump chamber may be contaminated with oil through reverse venting via the shaft seal.

**Caution**  
**Non-compliance with the following precautions can cause damage to the pump.**

## Safety information

- It is recommended to fit a non-return exhaust valve (P/N 119 011) in order to prevent the pump from running backwards.
- The pump must only be operated with all covers in place so as to ensure adequate cooling of the pump.
- The pump must only be operated at the specified frequency.
- Before pumping condensable vapours the ScrewLine should have attained its operating temperature. If an optional gas ballast is present, it should be used. The pump will attain its operating temperature about 30 minutes after switching on. During this time, the pump should be separated from the process by a valve in the intake line, for example.
- If condensable gases are pumped by the ScrewLine, the pump should be purged for about 15 minutes with an inert gas or air (depending on the application in each case) before switching the pump off. This should also be done before cleaning the pump chamber.
- Do not clean a pump which is still warm on it outside with water, since the cooling shock can cause a rotor crash.
- In the case of such applications which involve larger amounts of condensate, the use of a condensate separator in the exhaust line is strongly recommended.
- The exhaust line should be laid so that it slopes down and away from the pump so as to avoid a backflow of condensed vapours into the pump.
- In order to avoid the transfer of vibrations from the ScrewLine pump to other connected pieces of equipment, we recommend fitting of corrugated hoses or compensators at the intake and the exhaust sides.

**Notes**  
**Of the following notes serve the purpose of utilising the pump to the best effect.**

- Before transporting the ScrewLine, the gear oil must be drained out as otherwise oil may enter to the sealing system.
- Lines and other vacuum connections should be clean and free of oil. This must be observed especially when having used oil-sealed pumps before. The state must be checked before commissioning; in the case of deviations any oil which may still be present can contaminate the pump with oil residues.
- The pressure in a pump which has been switched off will rise to the ambient pressure within a few seconds. In such a case the pump is vented backwards through the exhaust as well as the drain of the shaft seal.

It is recommended to install the non-return exhaust valve (P/N 119 011) in order to avoid reverse venting.



# 1 Description

## 1.1 Area of Application

The ScrewLine has been developed specifically for the special requirements of industrial applications.

Typical areas of application are: vacuum furnaces, metallurgical systems, brazing systems, coating technology, (freeze) drying, packaging, research and development etc.

The standard ScrewLine vacuum pumps have been designed to pump air or inert gases in the pressure range between atmospheric pressure and the ultimate pressure of the pump. If other gases are to be pumped with this pump, please consult Leybold first.

When operating the pump with the SP-Guard, the information provided also in Operating Instructions GA 02.495 must be observed under all circumstances.

The standard versions of the ScrewLine pump are not suited for pumping any toxic, caustic, combustible and/or explosive gas mixtures. If such gas mixtures should be present in your application please consult Leybold first.

If gases are to be pumped which in contact with air will form explosive mixtures please consult Leybold for advice about suitable protection means. The ScrewLine pumps must not be operated in explosion hazard and/or areas in which combustible materials are present.

Gas mixtures with an oxygen share of > 21 percent by volume must not be pumped.

If in doubt contact Leybold for more information.

The pumps have not been designed to pump liquids. Suitable protection means must be introduced.

If in doubt contact Leybold for more information.

Each application has its special requirements. Your contact at Leybold will be pleased to inform you about the specific uses of the ScrewLine pump in each case.

### Note

### Warning



### Caution

# 1.2 Principle

## 1.2.1 Design

The ScrewLine is a dry compressing screw-type vacuum pump capable of a maximum pumping speed of  $250 \text{ m}^3 \times \text{h}^{-1}$ .

It has been developed specifically for the special requirements of industrial applications. For this reason the ruggedness of the pump was a main design criterion.

The screw shaped rotors are fitted to two horizontally arranged shafts and revolve without making contact within the pump chamber. The shafts are synchronised by a toothed gear. The shafts are driven via a further gear stage by an electric motor.

In vacuum pumps, the seals and the bearings on the vacuum side are always a potential source for a breakdown.

On the one hand lubricants may enter from the bearing into the vacuum process and on the other hand aggressive process media can endanger the bearings.

These disadvantages are avoided by the “cantilevered” arrangement of the rotors. The ScrewLine is equipped with two cantilevered screw type rotors which are guided by oversized shafts and bearings. The bearings are both located both in the gear chamber of the pump.

A further advantage of the cantilevered arrangement is that the pump chamber is easily accessible without having to disassemble any bearings. Thus any possibly required cleaning operations necessary due to the influence of the process can be run easily.

The cantilevered rotors minimise the risk of bearing damage and also reduce on-site maintenance to a minimum.

Shaft seals are in the case of the ScrewLine pump only required on the delivery side of the rotors. Owing to the small pressure difference between exhaust and gear, simple and reliable seals can be provided. The two shaft seals consist of a combination of a piston ring and a labyrinth seal thus making almost no contact so that the seals will be almost free of wear.

In standard applications no purge gas will be required at the seals. However, if demanded by the process conditions, a purge gas unit from Leybold Vacuum (P/N 119 031) may be connected.

The ScrewLine is air-cooled. A radial fan supports the cooling effect for the casing which is equipped liberally with cooling fins.

Depending on requirements, the ScrewLine pumps may be combined with Roots pumps so as to attain higher pumping speeds at lower pressures.

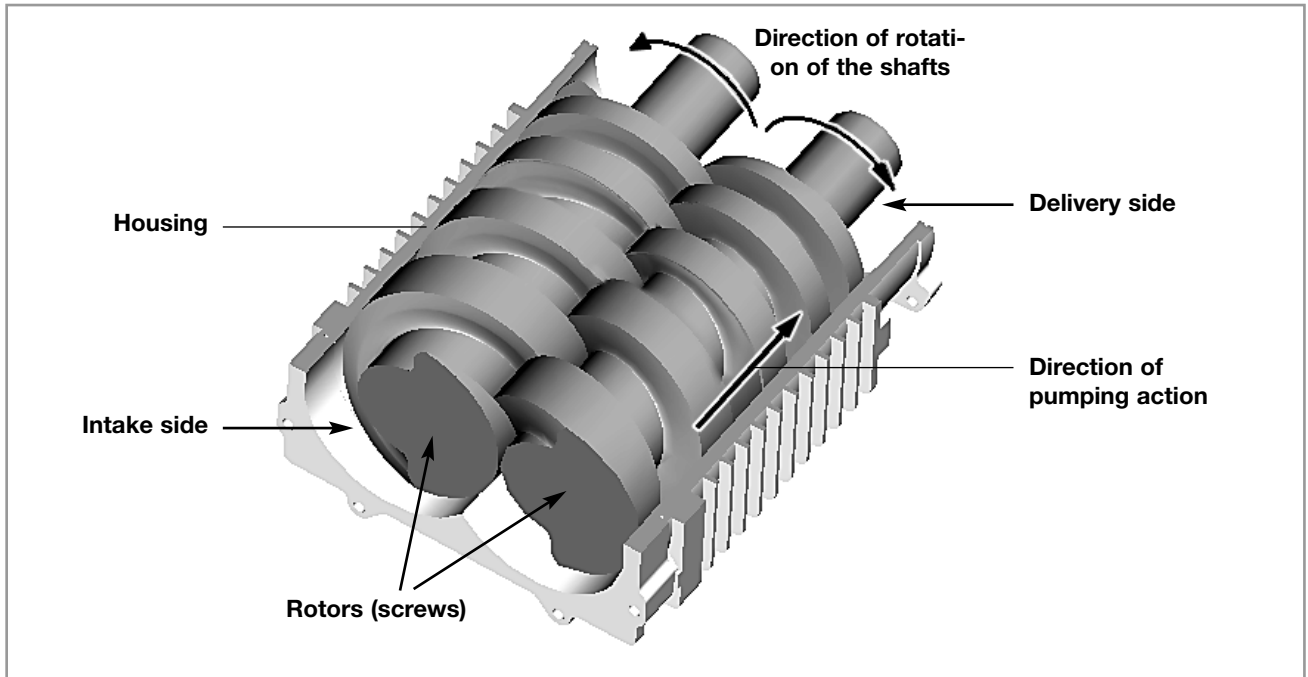

Fig. 1 Principle of operation of a screw pump

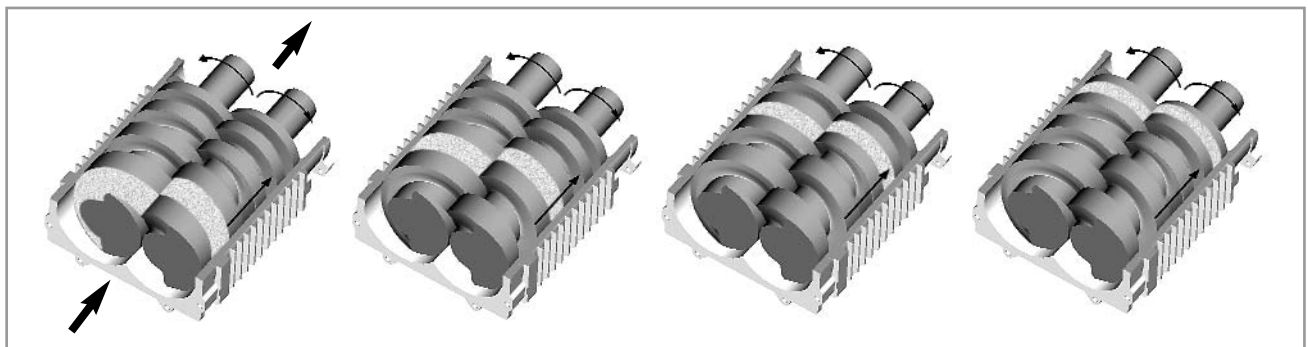

Fig. 2 Compression principle and the direction of pumping action within a screw pump

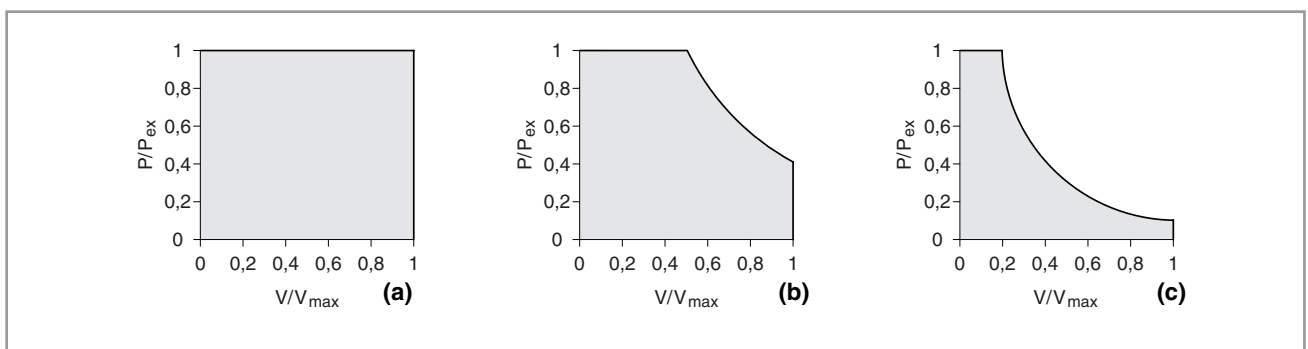

Fig. 3 pV diagrams of screw pumps

### 1.2.2 Principle of Operation

In the ScrewLine vacuum pumps the pump chamber is formed by two synchronised displacing rotors and the housing.

A pair of tightly intermeshing right-handed and left-handed threads is used to implement with only very few components a large number of stages and thus very low ultimate pressures.

Figures 1 and 2 show how by the two rotors and the housing several chambers are created which allow the gas to be compressed. Since the rotors turn in opposing directions, the chambers “move” steadily from the intake to the delivery side of the pump (Fig. 2) so that the gas is conveyed in a low-pulsation manner.

The continuous pumping action for the gas without the need of having to deflect the gas will also allow pumping of particles entrained in the gas and also vapours to a limited extent.

As in the case of other dry compressing (slot sealed) vacuum pumps, also in the case of screw pumps very tight slots need to be maintained between the components. Otherwise the leaks caused by the pressure drop would have a negative effect on both pumping speed and attainable ultimate pressure. Moreover, the pump might heat itself up too much due to unfavourable thermodynamic processes.

During operation the design of the ScrewLine ensures that the slots are maintained within the operational limits of the pump. In order to limit the temperatures attained by the components, the housing of the pump chamber is air-cooled. Also the rotors themselves are cooled: by oil which is pumped through bores in the rotor shafts and which also lubricates the bearings and the toothed wheels of the pump’s synchronising gear. Thus an uniform temperature spread is attained within the pump.

The amount of “inner compression” has a significant influence on the temperature level within a vacuum pump. In the case of a foreline pump, most of the work on compression is done while the gas is being ejected against the delivery pressure, i.e. in the last stages of the pump. For this reason in the case of the ScrewLine the volume of the gas is already significantly reduced at pressures which are as low as possible so as to minimise this work done on compression. In this way the power requirement of the pump is reduced and less heat needs to be dissipated.

Fig. 3 shows the pV diagram of screw pumps: (a) without inner compression, (b) with inner compression against the face side of the pump chamber and (c) by reducing the chamber volume along the rotor. The surface areas enclosed in the pV diagram are in each case proportional to the power uptake of the pump. It is apparent that the most efficient method is to compress the gas which is to be pumped by reducing the axial pitch of the rotor from the inlet to the delivery side (Fig. 2) so that the chamber volume is already reduced at low pressures (Fig. 3c). In this way a power consumption can be attained which is comparable to that of rotary vane pumps.

## 1.3 Technical Data

(Delivery versions - see Chapter 1.5)

ScrewLine		SP 250 (50 Hz)	SP 250 (60 Hz)
<b>Type</b>		<b>dry compressing screw vacuum pump</b>	
Effective pumping speed (- 5 %)	m <sup>3</sup> x h <sup>-1</sup>	270	330
Ultimate pressure, total	mbar	≤ 0.01	≤ 0.005
Permissible exhaust back pressure	mbar	$p_{\max}=p_{\text{amb}} + 200 \text{ mbar}$ $- 50 \text{ mbar}$	$p_{\max}=p_{\text{amb}} + 200 \text{ mbar}$ $- 50 \text{ mbar}$
Maximum permissible intake pressure	mbar	1030	1030
Noise level <sup>1)</sup>	dB (A)	≤ 75	≤ 75
Total weight, approx.	kg	450	450
Dimensions (L x W x H)	mm	1350 x 530 x 880	1350 x 530 x 880
Permissible ambient temperatures	°C	10 to 40	10 to 40
Contamination grade <sup>2)</sup>		3	3
Water vapour tolerance (with gas ballast)	mbar	60	75
Relative humidity of the air <sup>3)</sup>	%	max. 95	max. 95
Installation location		0 - 3000 m (above sea level)	0 - 3000 m (above sea level)
Pump monitoring with SP-Guard		Processing through system controller	Processing through system controller
Temperature sensor in the motor coil		PTC 160 °C - 5 °C	PTC 160 °C - 5 °C
<b>Motor</b>			
Speed	rpm	2920	3505
Nominal power rating	kW	7.5	12
Nominal power rating at ultimate pressure	kW	5.9	7.2
Nominal current at operating voltage and 50 Hz, ΔΔ		29.0 A / 200 V	--
Nominal current at operating voltage and 50 Hz, Δ		14.5 A / 400 V	--
Nominal current at operating voltage and 60 Hz, ΔΔ			39.0 A / 210 V
Nominal current at operating voltage and 60 Hz, Δ			18.4 A / 460 V
cos φ		0.84	0.88
Type of motor protection		IP 55	IP 55
Heat protection class		F	F
<b>Operating agents</b>			
Cooling		Air	Air
Approved type of oil: Anderol 555	I	7 (Initial filling) <sup>4)</sup>	7 (Initial filling) <sup>4)</sup>
<b>Materials</b>			
Components in contact with the gas		Aluminium, aluminium anodised C steel, CrNi steel, grey cast iron, FPM	
<b>Flanges</b>			
Intake flange DN 63		ISO 1609-1986 (E)-63 DN 63 ISO-K ASME B16.5 NPS 3 Class 150 EN 1092-2-PN 6 - DN 65	
Exhaust flange		ISO 1609-1986 (E)-63 (DN 63 ISO-K)	

<sup>1)</sup> with blanked off lines and at ultimate pressure, in accordance with ISO 4871

<sup>2)</sup> in accordance with EN 50178

<sup>3)</sup> in accordance with EN 60721-3-3

<sup>4)</sup> provided in the factory

# Description

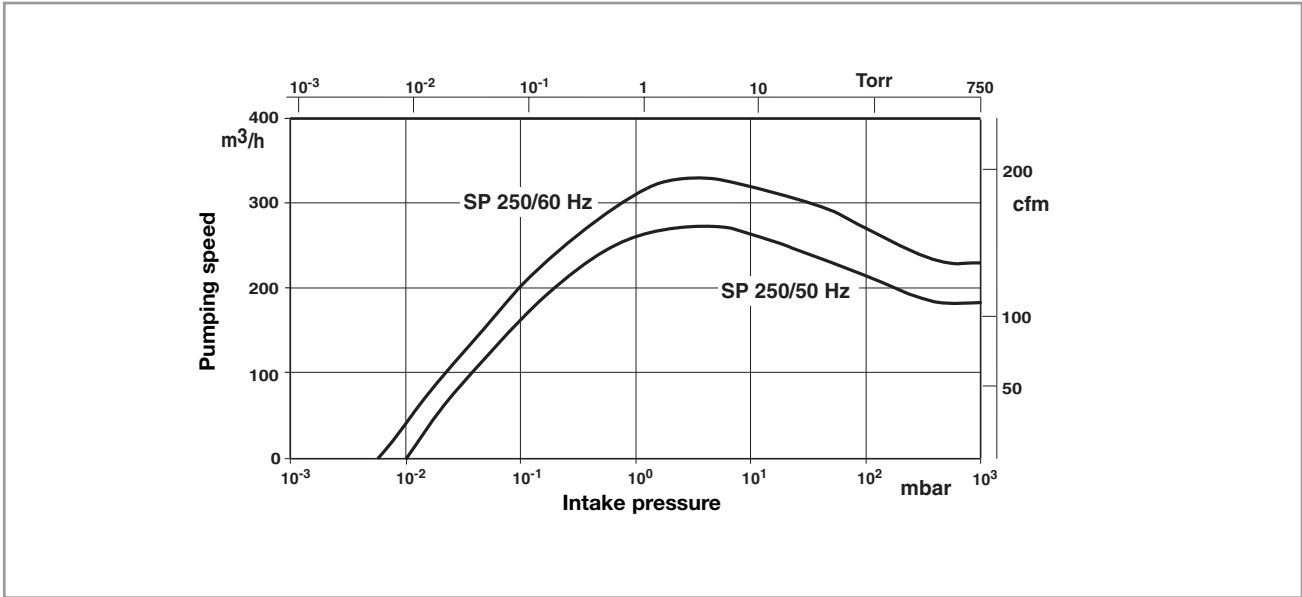

Fig. 4 Pumping speed curve of the ScrewLine SP 250 at  $S_{eff}$  50 Hz and 60 Hz

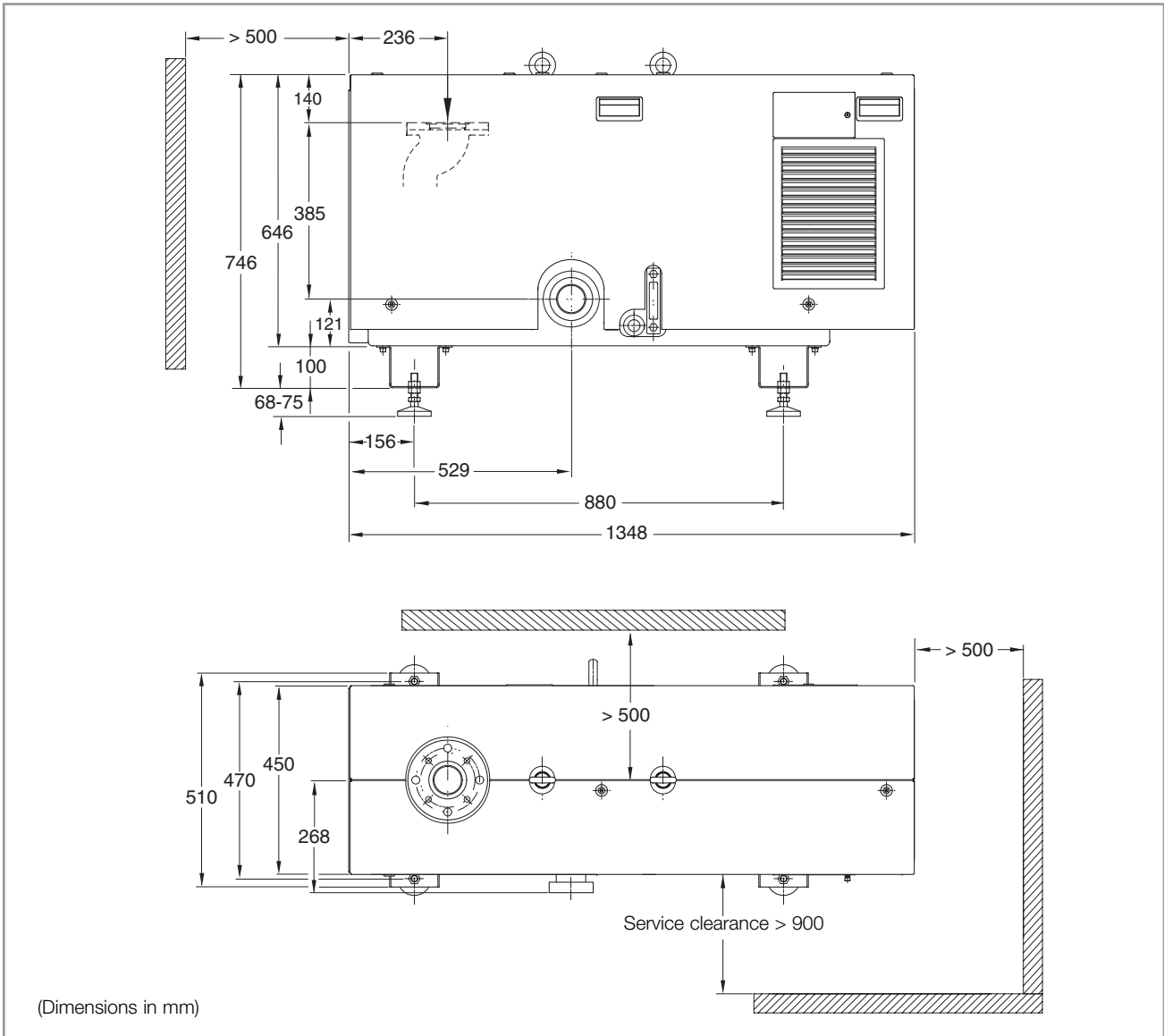

Fig. 5 Dimensional drawing for the ScrewLine SP 250

### 1.3.1 Available Documentation

	GA02412	KA02412	KA02412	KA02495	KA02487	KA02484	KA02483	KA02480	KA02486
P/N	ScrewLine SP 250 50/60 Hz	Manually operated gas ballast	Solenoid gas ballast	SP-Guard	Silencer SP 250	Purge gas	Roots	Filter- adapter	Non- return valve
115 001	●	●		●					
115 002	●		●	●					
115 003	●		●	●		●			
115 004	●	●							
115 005	●		●						
119 002					●				
119 011									●
119 019								●	
119 022							●		
119 031						●			

## 1.4 Supplied Equipment

The ScrewLine is supplied ready for installation and connection.

The ScrewLine pump is delivered with:

- An integrated motor
- The required amount of gear oil (is supplied separately)
- SP-Guard monitoring system
- Gas ballast facility
- An inlet screen which prevents the ingress of smaller items through the intake of the pump
- 2 crane eyes for transporting the pump
- 2 cable fittings for the junction box
- Square key for disassembly/assembly of the cover and for opening the fan housing
- Operating Instructions

Intake and exhaust ports are sealed with foil. Remove this foil and also the desiccant inside before switching on the pump.

For the purpose of shipping the pump, the pump has been affixed to a special pallet. Retain this pallet in case the pump needs to be returned.

#### Note

The electrical connections to the pump must be provided by suitably trained staff of the customer (see Chapter 2.3 Electrical Connection).

## 1.5 Pump Versions

The following pump versions are available:	P/N
■ Version for 50/60 Hz operation with SP-Guard and manually operated gas ballast	<b>115 001</b>
■ Version for 50/60 Hz operation with SP-Guard and solenoid gas ballast	<b>115 002</b>
■ Version for 50/60 Hz operation with SP-Guard, solenoid gas ballast and purge gas control unit	<b>115 003</b>
■ Version for 50/60 Hz operation with manually operated gas ballast	<b>115 004</b>
■ Version for 50/60 Hz operation with solenoid gas ballast	<b>115 005</b>

## 1.6 Accessories

	P/N
■ Exhaust silencer with condensate drain Here please note the Brief Instructions - KA 02.487	<b>119 002</b>
■ Non-return valve Here please note the Brief Instructions - KA02486	119 011
■ Filter adapter 65 ISO-K Here please note the Brief Instructions - KA02480	119 019
■ Roots pump adapter for RUVAC 1001/501 Here please note the Brief Instructions - KA02483	119 022
■ Optional exhaust flange	119 023

Stability of the pump when using LEYBOLD accessories is ensured. If other accessories are fitted then the user himself will be responsible for maintaining stability of the pump.

## 1.7 Spare Parts

- Maintenance kit level 1 (for gear oil change) EK 110000820

**Contents:**

5 litres ANDEROL 555, oil filter cartridge,  
O-ring for filter housing, gasket for oil sight glass,  
gasket for oil inlet and square key

Additional spare parts are available from the Leybold service offices.

## 1.8 Storing

Before storing the pump let in run dry for at least 30 minutes.

Place a bag with desiccant in the exhaust flange and the intake flange and seal off the flanges with foil.

Before storing the pump for a longer period of time drain out the oil.

Package the pump in polyethylene foil and seal it off air-tight.

**Storage conditions**

Temperature	-20°C to +60°C
Storage location	dry
Maximum humidity of the air	95%, non-condensing



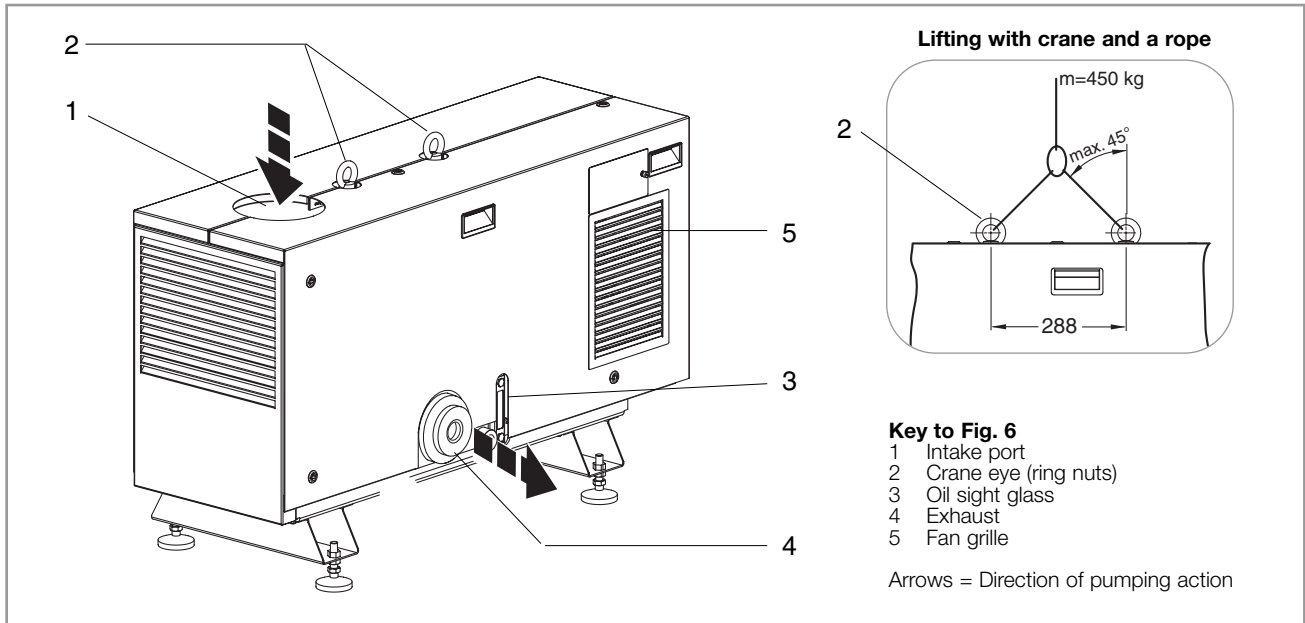

Fig. 6 Transport and connection components as well as inspection locations on the ScrewLine SP 250

## 2 Operation

### 2.1 Placement

The standard pump is not suited for being installed in explosion hazard areas. Please contact us first when planning such an application. Before installing the pump it must be disconnected from all sources of electrical power and protected against being switched on inadvertently. Only trained staff may install the pump.

Please observe the safety regulations.

#### Warning



#### 2.1.1 Transport

When transporting the ScrewLine pump please note its total weight first (see Chapter 1.3 Technical Data).

Use only approved means to transport the pump. The transport means must be so rated that they can adequately handle the weight of the pump.

Located on the top side are as standard 2 crane eyes (Fig. 6, item. 2), in accordance with DIN 582-M16-C15N. Only these ring nuts may be used when lifting the pump with a crane. When using ropes to lift the pump at the ring nuts, please observe the maximum permissible angles as given in Fig. 6.

When transporting the pump with fork lifters or alike, the pump must be secured on the supplied pallet or a suitable other pallet.

The ring nuts have been secured and must not be loosened.

The frame of the pump has not been designed for use with fork lifters or alike since there is the risk that the pump may topple when accelerating or moving up ramps.

#### Warning



### Warning



However, the pump's frame is rugged enough for attaching lifting means for the purpose of installing or positioning the pump within a system. When doing so note the risk of slipping and toppling. If required secure the pump.

For transporting, the silencer must be disassembled as otherwise there is the risk of toppling.

### Caution

Before transporting the pump always drain out the gear oil from the pump first.

## 2.1.2 Floor

The ScrewLine should be placed on a flat and level surface.

### Warning



The foundations carrying the pump must be rated as a minimum requirement at 1,000 kg/m<sup>2</sup>.

An inclination of over 10 degrees from the vertical axis is not permissible because of the risk of toppling.

### Caution

When operating the pump, an angle exceeding 2 degrees from the vertical axis is not permissible as otherwise oil may enter into the sealing system.

## 2.1.3 Air Cooling and Pump Covers

The ScrewLine is mostly cooled via its housing with cooling fins on most of its area and with the aid of a radial fan.

### Caution

The location where the pump is installed must be selected so that an adequate supply and discharge of cooling air is ensured. The minimum clearances are given in the dimensional drawing for the pump (Fig. 5).

As standard the ScrewLine is equipped with covers. These ensure uniform cooling of the ScrewLine and have, besides the protective function, also a silencing effect.

### Warning



The noise level of the ScrewLine corresponds at ultimate pressure with fitted silencers or connected exhaust line to the values given in Chapter 1.3 Technical Data. In all other operating modes and with other equipment, higher values may be attained. Suitable hearing protection measures must be introduced.

Surfaces under the covers of the ScrewLine may attain temperatures over 70 °C. If during maintenance work the covers are removed, there is the risk of suffering burns.

Therefore always wear the required protective clothing.

With all covers in place there only remains the risk of suffering burns at the exhaust port.



Do not operate the ScrewLine with the covers only partly in place (when disassembling one side, for example) since this will impair the steadiness of the air flow cooling the pump.

Make sure that the air cooling arrangement is not impaired. When operating the pump do not leave any items (pieces of cleaning cloth, for example) on the cooling fins of the pump chamber. Clean the cooling fins when they are found to be very dirty.

The pump may be damaged if the cooling air flow is restricted.

**Caution**  
**Impairment of air cooling**

### 2.1.4 Ambient Conditions

The pump may be operated under the ambient temperatures specified by the Technical Data.

At higher ambient temperatures or in the case of a dirty oil cooler, the temperature of the oil can increase to unacceptably high levels. In the case of high ambient temperatures or in the case of dusty ambient conditions the oil cooler should be checked more often (see Maintenance).

The maximum permissible ambient temperature must not be exceeded.

The ScrewLine must be installed such that the side of the exhaust flange remains easily accessible. From this side all maintenance and installation work can be done (see Fig. 5/service clearance).

**Caution**

### 2.1.5 Installation Location

At installation locations between 0 and 3000 m above sea level the following applies to the exhaust pressure  $p_{ex}$  at the exhaust:

Maximum exhaust pressure relative to ambient pressure ( $p_{amb}$ )

$$p_{max} = p_{amb} + 200 \text{ mbar}$$

Minimum exhaust pressure relative to ambient pressure ( $p_{amb}$ )

$$p_{min} = p_{amb} - 50 \text{ mbar}$$

Should the exhaust pressure drop below the ambient pressure in the exhaust area, then oil may be displaced from the area of the shaft sealing rings into the pump chamber.

**Caution**

## 2.2 Connection to the System

**Warning**



Before installing the pump it must be disconnected from all voltage sources and protected from being switched on inadvertently. Only trained staff may install the pump.

Observe all safety regulations.

Avoid exposing any part of the human body to the vacuum. For this reason never operate the ScrewLine without having fitted an intake line or a blank flange first.



The ScrewLine must not be operated with an open intake port (risk of suffering injury by rotating parts which are within reach).

Any backflowing of detrimental gases or gas mixtures from the delivery side must be excluded.

When connecting several pump systems, pressure differences between inlet and outlet can result in uncontrolled turning of the rotors. This can severely damage the pump. Moreover, this represents a potential hazard during maintenance work. Here, if necessary, the nonreturn valve (P/N 119 011) can be used.

### 2.2.1 Connections at the Intake Side

Remove protection foil and desiccant from the intake port (6/1).

**Caution**

When fitting the intake line be sure to select the right materials. These must be capable of resisting the pumped medium.

The connecting flanges must be clean and undamaged so as to ensure a leaktight vacuum system.

At the intake side of the pump (6/1) lines which are as short as possible having a minimum nominal width of DN 63 should be used. The same applies also to components like valves fitted in the lines.

**Caution**

The cross section of the intake line should at least match the size of the connections on the pump.

The intake line should be clean and free of oil. Dirt, like welding beads or cinder must be removed with care from the intake line.

**Caution**

The intake line should be fitted to the pump using a flexible pipe connection so that no mechanical strains will be present.

Always make sure that no small items (bolts, nuts, washers, pieces of wire etc.) enter into the pump through its inlet. For this reason always fit the inlet screen which is supplied as standard with each pump.

Ensure that the piping is supported if required, in particular in those cases when other components like valves, separators etc. are installed upstream of the pump.

The maximum permissible weight on the intake port of the ScrewLine is 50 kg.

**Caution**

**2.2.2 Connections at the Delivery Side (Exhaust)**

Remove the protection foil and desiccant from the exhaust flange (6/4).

It is strongly recommended to always operate the ScrewLine with a connected and suitable exhaust line. The exhaust line should be laid so that it slopes down and away from the pump so as to prevent condensate in the exhaust line from backstreaming into the pump.

Alternatively a condensate separator can be provided directly downstream of the exhaust flange. The filling level of the condensate separator needs to be monitored regularly so that the gas may flow out of the exhaust without being obstructed.

In the case of the optionally available silencer, the condensate separator has already been integrated.

It must be made absolutely sure that any blocking devices installed in the exhaust line, valves or alike, are opened before starting the pump.

The ScrewLine may generate at the exhaust and with a blocked exhaust line, pressures significantly over 1.5 bar (abs). Such pressures can cause damage to components which do not comply with the regulations for pressurised vessels.

The diameter of the exhaust line (6/4) should at least match the diameter of the connection at the pump.

The piping should consist of materials capable of resisting the discharged medium.

The piping should be connected to the pump without straining.

The maximum permissible exhaust back pressure must not exceed + 200 mbar/- 50 mbar with reference to atmospheric pressure.

The temperature of the discharged gases and the exhaust port itself may exceed 70 °C. There is the risk of suffering burns!

**Warning**



**Caution**

**Warning**



When connecting the exhaust side to an exhaust gas collecting line, the installation of a non-return valve (P/N 119 011) downstream of the exhaust is recommended. This will reliably prevent any gases from flowing back through the exhaust into the pump.

## 2.3 Electrical Connection

**Warning**



The electrical connections must be provided by authorised staff of the customer himself.

The electrical connections must only be provided by a trained electrician in accordance with VDE 0105 (DIN EN 50110-1) and in accordance with VDE 0100 (IEC 60364) guidelines.

During all work on the ScrewLine, the mains voltage must be switched off and protected against being switched on inadvertently.

The pump itself is not equipped with any switches. Protection arrangements need to be implemented by the customer.

After a mains power failure the pump will run up automatically again when the mains power returns.

- If thus in connection with the process application there results a risk potential, then it needs to be ensured that the pump can only restart after a manual reset. This also applies to emergency shutdowns (this needs to be implemented from the side of the customer).
- In case of an overload the pump needs to be separated from the mains power by a main switch so as to prevent the pump from cycling on and off (cycling between overload and cool-down phase). Only after the cause for the overload has been removed may the main switch be switched on manually again

In the case of a failure of the electrical power supply, greater pressure differences may occur between inlet and outlet possibly causing the pump to turn backwards. The installation of a corresponding valve can prevent the pump from turning backwards.

Please note all safety regulations. Before providing the electrical connections, note the ratings required for the switches.

The ScrewLine must only be operated at the stated frequency as otherwise the pump may suffer damage.

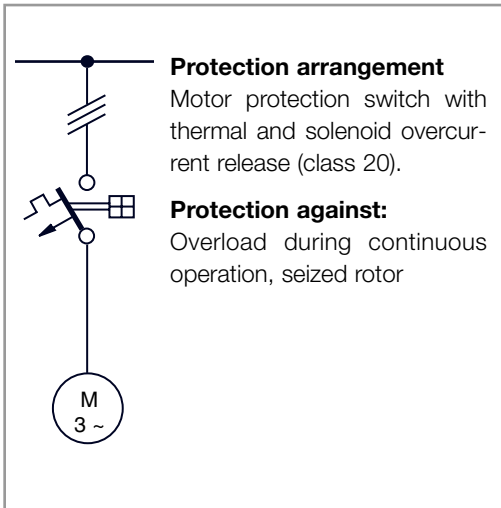

Fig. 7 Circuit example: motor protection

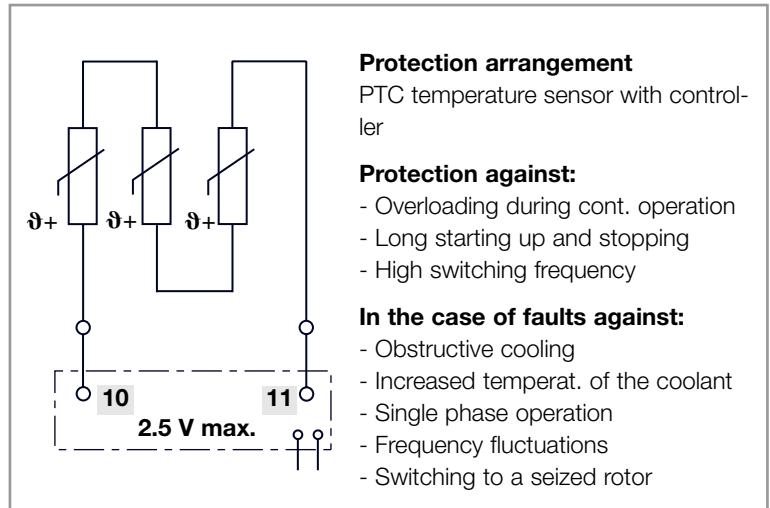

Fig. 8 Circuit example: PTC temperature sensor

### 2.3.1 Motor Protection

**The motor must only be operated with overprotection circuitry in place.**

The electric motor must be protected with a thermal overload protection of class 20 (in accordance with a I EC 60947-4). Motor protection switches which belong to class 20 respond with a delay, after 20 seconds at the latest.

The setting for the motor protection switch which corresponds to the local requirements can be taken from the following U/I diagram (diagram 1 for  $\Delta$ - connection (applies analogously also for  $\Delta\Delta$ - connection)).

When connecting the pump in a  $\Delta\Delta$ -circuit at  $U/2$  the values are read off from the diagram ( $\Delta$ -circuit) for  $2 \times U/2$  need to be doubled.

If briefly an unacceptably high temperature should occur in the motor coils, then this condition is detected by the integrated PTC resistor. The PTC resistor is connected to the terminals 10 and 11 in the junction box (12/1) (see Fig. 7 and 8). Connect these terminals exclusively via a corresponding actuator (for example Klöckner Möller EMT6DBK) with electrical isolation to the pump's control system.

The PTC resistor provides a means of protection which in the case of bad cooling, a temporary failure of a mains phase or in the case of frequency variations will offer effective protection and will prevent costly damage to the motor coils.

The number of operating hours of the ScrewLine should be acquired on the side of the system by means of an operating hours counter, also when using the SP-Guard monitoring system

The local connection conditions will possibly necessitate means for the purpose of reducing the surge currents upon switching the pump on.

#### Caution

#### Avoidance of high surge currents

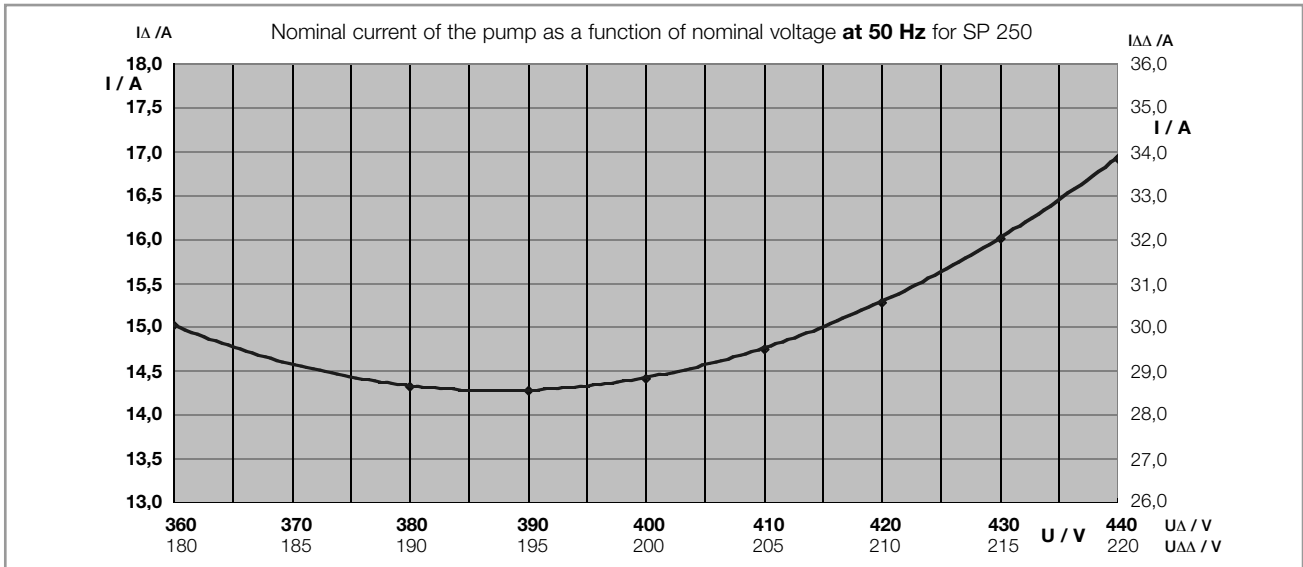

Diagram 1 Characteristic of the motor protection switch for delta circuit (Symbol  $\Delta$  respectively  $\Delta\Delta$  )

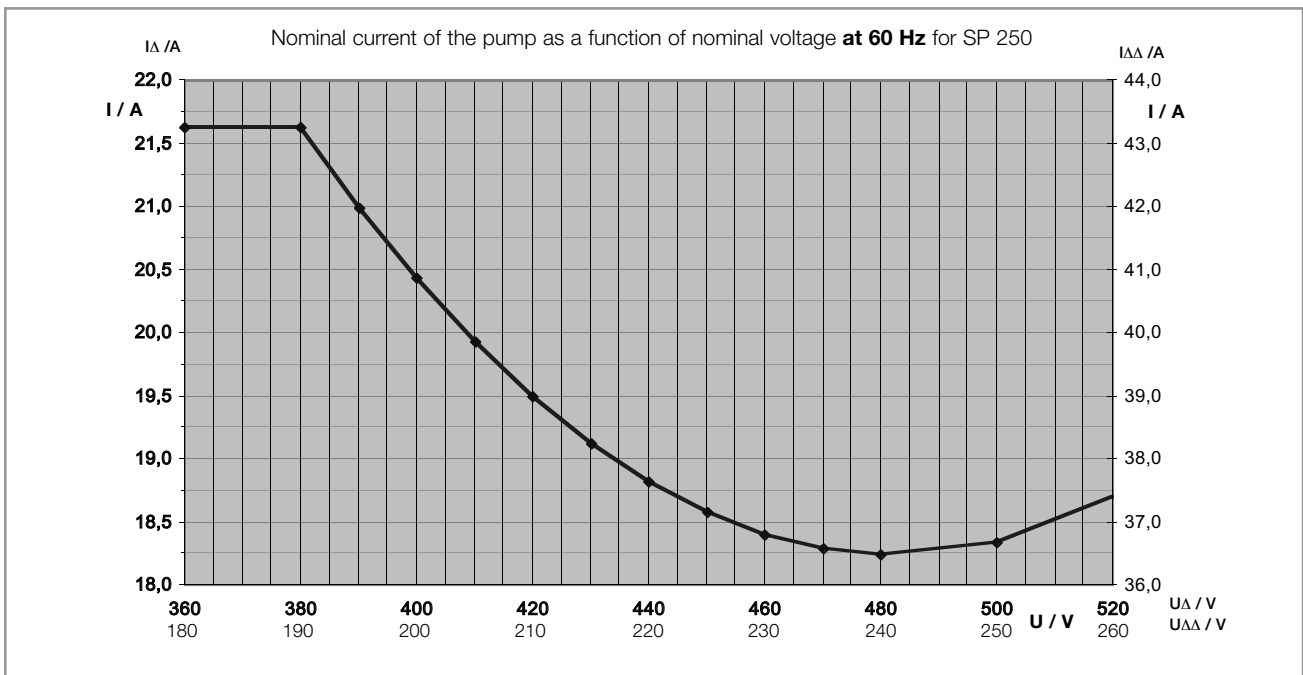
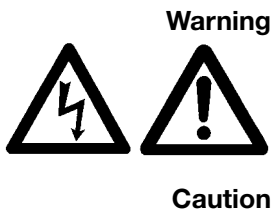

Diagram 1.1 Characteristic of the motor protection switch for delta circuit (Symbol  $\Delta$  respectively  $\Delta\Delta$  )

### 2.3.2 Star/Delta Start-up Circuit



This installation work needs to be done by authorised expert staff.

In the case of this circuit (star circuit) a lower voltage is applied to the motor coils, resulting in a lower switch-on current.

During this phase also power and torque of the motor are lower.



In order to attain the operating levels for torque and power rapidly, the start-up phase should be as short as possible, approximately 4 to 5 seconds. Thereafter the switchover to continuous operation (delta circuit) should occur.

Here also a motor protection switch for heavy run-up (class 20) should be used.

### 2.3.3 Soft Start

In order to reduce the current drawn from the mains supply, the supply voltage applied to the motor is controlled electronically during the start-up period.

During the start-up period the motor must reliably attain its rated values. The setup start voltage should be approximately 65 to 70% of the nominal voltage.

The optimum parameter settings needs to be made by a trained electrician.

The use of a motor protection switch for heavy run-up (class 20) is mandatory.

**Caution**

### 2.3.4 Mains Connection

The pump is not equipped with any switches. Protection schemes must be provided externally by the customer.

**Caution**

The mains power needs to be supplied via an external mains switch with ON/OFF key by the customer.

The mains connection needs to be provided in accordance with the type of motor protection. The mains supply must match the mains power rating of the motor.

After a mains power failure the pump will run up automatically as soon as the mains power returns.

**Warning**



The motor rating is given in Chapter 1.3 “Technical Data”.

As a rule, the pumps are supplied by Leybold turning in the clockwise direction on the load side, with the direction of rotation being anticlockwise for the ventilation side.

**Caution**

For the power connecting lines from the side of the customer a clockwise rotating field needs to be ensured. Please check this with a direction of rotation measuring instrument.

After having connected the pump, check the direction of rotation of the motor. This should be done at atmospheric pressure in the intake line (switch the valves accordingly). Let the pump run up briefly (about 1 s). During this time observe the fan’s direction of rotation. The direction indicating arrow can be found at the junction box - vertical wall - on the operating side besides the fan housing. View from the load side looking onto the fan housing.

**Check the motor’s and direction of rotation!**

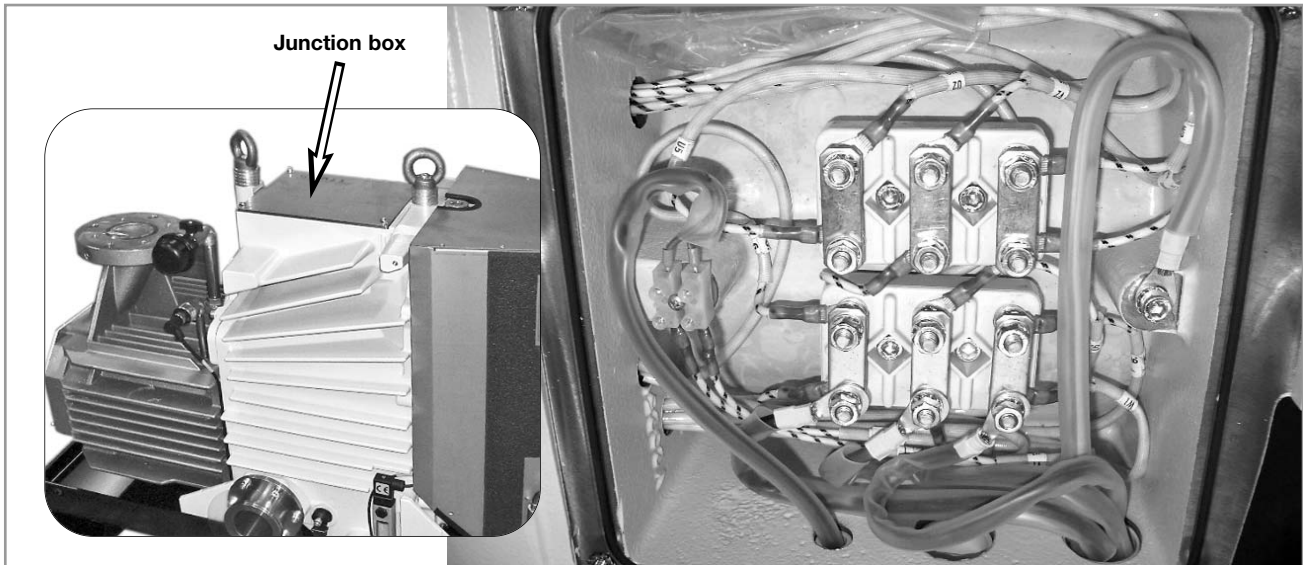

Fig. 9a Electrical connection from the customer's side at the junction box  
The connecting wires are protected by an additional piece of silicone tubing.

### Warning



Do not open the fan housing by unscrewing the cooler since there is the risk of suffering injury by the rotating fan.

### Caution

When incorrectly connecting the motor of the pump, it may only be operated running in the reverse direction for a maximum of three seconds. Longer operation in the reverse direction will cause damage to the pump.

It is best to check the direction of rotation involving two persons. If possible check the direction of rotation of the ScrewLine with the intake line open but with the inlet screen secured in place.

### Warning



Except when checking the direction of rotation the pump must never be operated with its housing open.

There is the risk of suffering injury due to hot surfaces. Moreover, sufficient cooling of the pump is not ensured when the housing is open.

### Warning

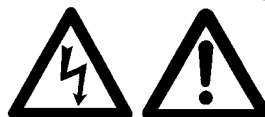

The line cross-section for the mains power supply needs to be calculated in consideration of the cable length and the available mains circuit breaker. Using a mains power supply line having a cross-section of at least  $4 \times 6 \text{ mm}^2$  is recommended.

A temperature resistance of the mains power supply line of at least  $105^\circ \text{C}$  must be ensured.

In case the temperature resistance is lower (for example  $80^\circ \text{C}$ ) the individual wires in the junction box of the pump need to be protected using the enclosed silicon hose pieces against thermal stress (see figure below). This also applies to the two connecting wires of the PTC resistor (terminals 10 and 11).

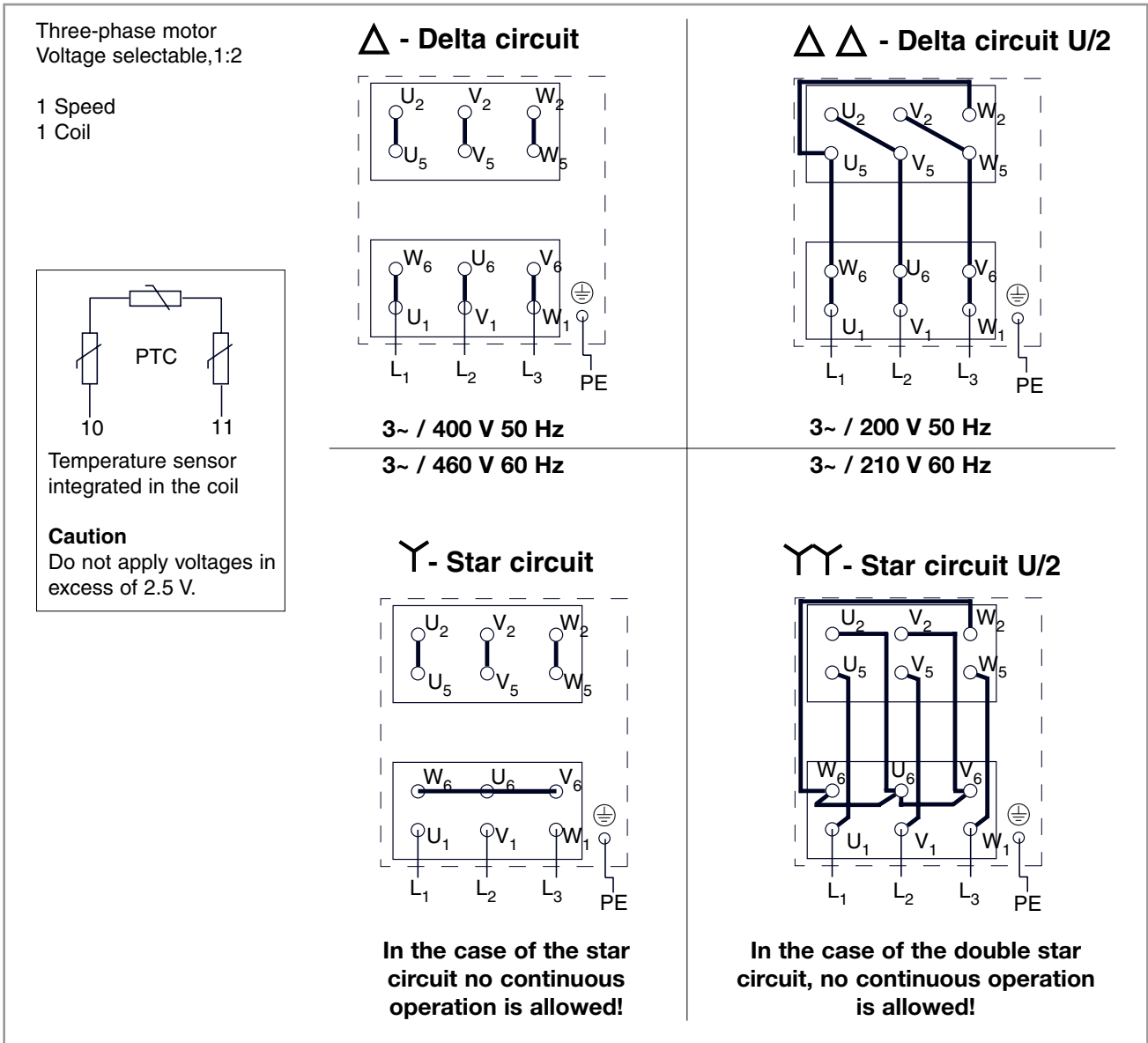

Fig. 9 Mains connection (figures in the junction box of the ScrewLine SP 250)

### 2.3.5 Power Failure

When connecting the pump to a vacuum chamber, a suitable valve (for example an electrically actuated isolating valve) needs to be provided on the intake side for blocking the intake line so as to prevent the pump from turning backwards in the case of a power failure.

If such a valve is not installed it is likely that the pump will suffer damage.

The valve needs to be controlled from the side of the system so that the intake line is blocked in the event of a power failure.

**Warning**

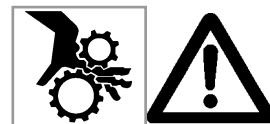

## 2.4 Commissioning

**Warning**

The pump must only be commissioned by trained staff.



### 2.4.1 Oil Filling for the Gear

**Caution**

The ScrewLine is supplied without oil in its gear. Due to testing work on the pump there remains a small quantity of oil in the gear.

Before commissioning, the separately supplied gear oil must be filled into the gear.

Please fill in thick oil slowly.

When doing so make sure that all aids used are clean so as to avoid contaminating the oil.

Use only lubricating oil which has been approved by Leybold.

The gear oil should be filled in at room temperature. At lower temperatures, the oil is thicker so that there then is the risk of overfilling gear chamber with oil.

For filling in oil, the cover section (11/1) on the exhaust side must be disassembled. For this unlock the closure screws (Fig.11/item X) at the cover of the ScrewLine (5 pieces) and remove the cover section.

**Caution**

For the closure screws you will require a special square key. This key is included with the ScrewLine.

**Remove the oil fill plug (see Fig. 10) and fill in the lubricant. When doing so, make sure that the oil level, after filling, will be at the level of the maximum mark (see Fig. 10) during standstill of the pump.**

**Caution**

The entire oil filling quantity amounts to 7 litres. Since after testing and draining the lubricant, some oil remains within the pump only approximately 5 litres of oil are filled in during initial commissioning.

It needs to be observed that the oil level is filled up to the **maximum mark during standstill** of the pump (see Fig. 10).

Overfilling the gear chamber can result in leakages through the drain and also into the pump chamber.

Clean the oil fill port and screw the oil fill plug (Fig. 10) in again using a gasket which is in perfect condition.

The oil fill port must be sealed air-tight.

For checking the oil level and for changing the oil see Chapter 3.1.1.

When switching the pump on and off the oil level may fluctuate visibly. During operation of the pump the oil level will be between the maximum and the minimum mark (see Fig. 10). As soon as the oil level during operation of the pump drops to the minimum mark, oil must be topped up.

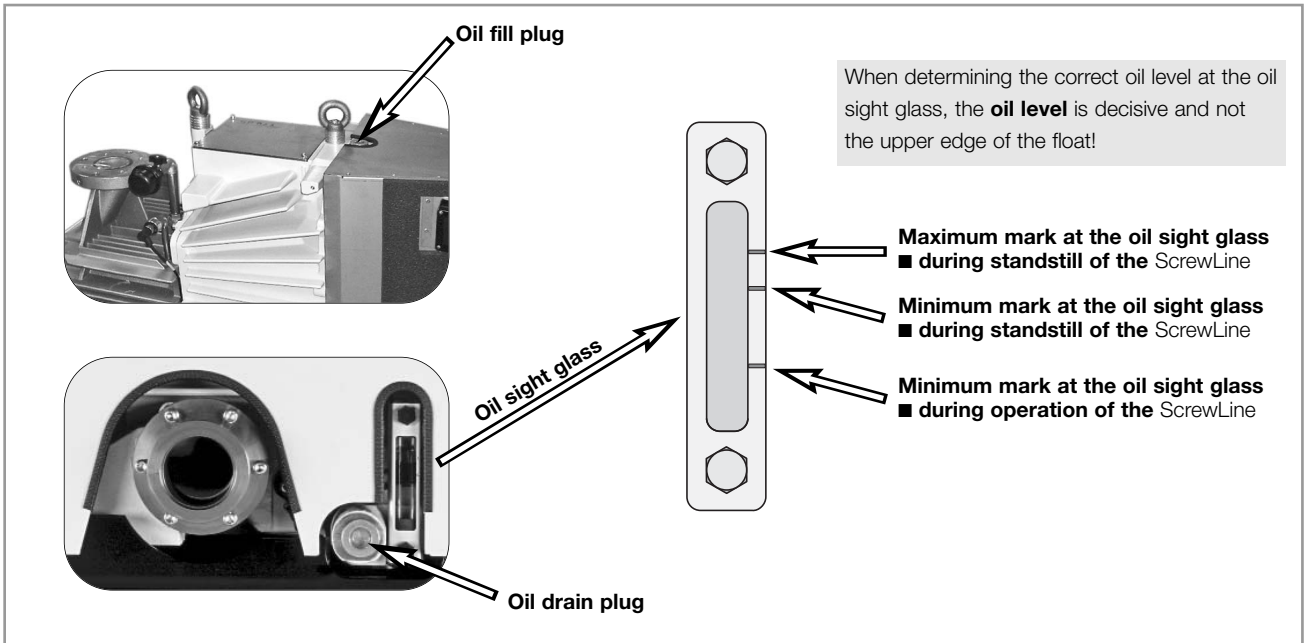

Fig. 10 Oil level at the oil sight glass of the ScrewLine SP 250

During operation the oil level will be approximately 15 mm below the standstill level.

The type of gear oil is specified in Chapter 1.3 “Technical Data”.

After having filled in the oil, the cover must be fitted once more.

The two cover sections are fitted in the reverse order as described in Chapter 2.4.1.

**Note**

When mounting the covers, the spigots of the cover halves must be inserted into the corresponding receiving bores. Thus proper seating of the cover halves is ensured.

Before starting up the pump, make sure that the pump and the attached accessories meet the requirements of your application and that safe operation is ensured.

Never clean in the oil sight glass with aggressive cleaning agents!

Avoid exposing any part of the human body to the vacuum. There is the risk of suffering injury. Never operate the pump while the intake port is open.

**Caution**

**Note**

**Warning**



Vacuum connections as well as oil-fill and drain ports must not be opened while the pump is running.

**Caution**

Compliance with the relevant safety instructions for the respective applications is essential. This applies to installation, operation and maintenance (servicing) as well as waste disposal and shipping.

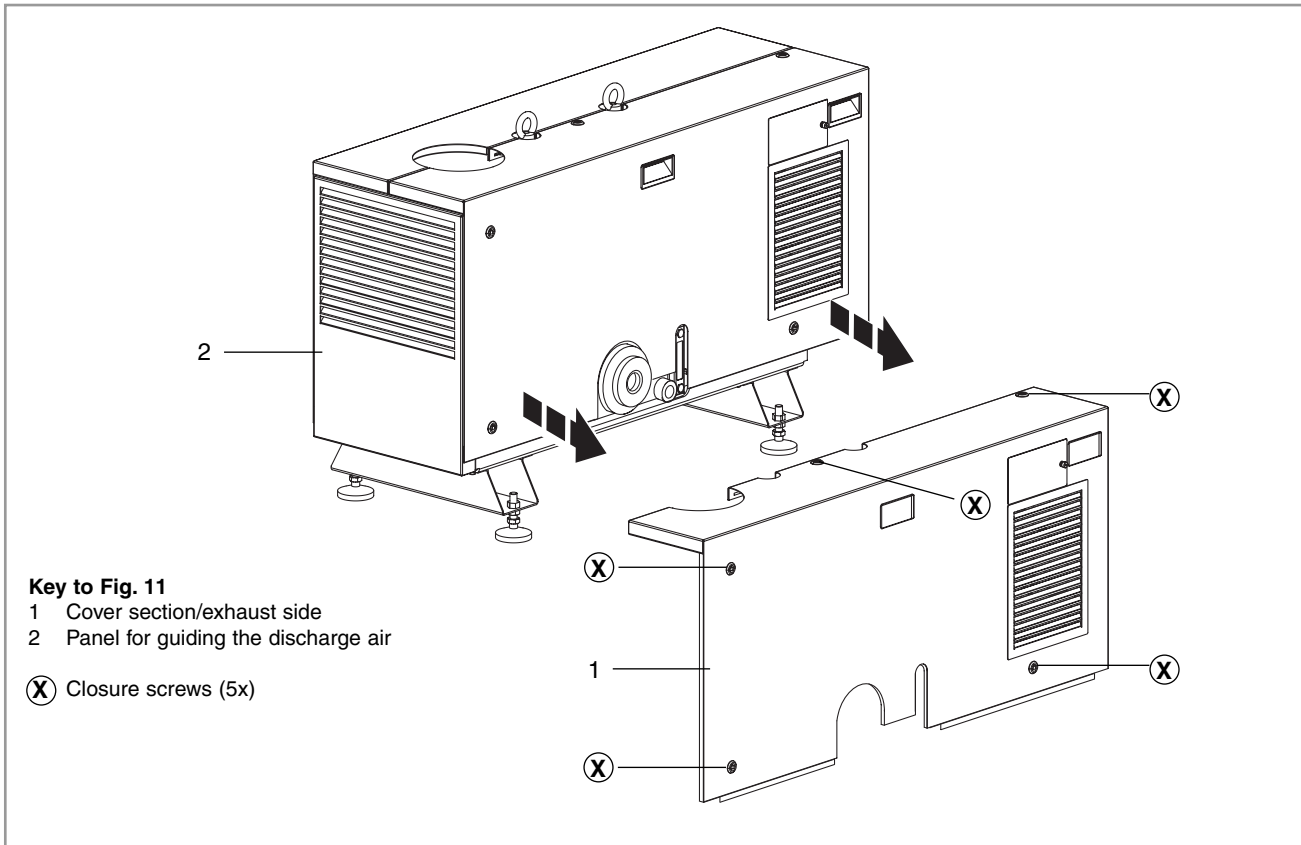

Fig. 11 Unlocking the closure screws and removing the cover section from the ScrewLine SP 250

### 2.4.2 Switching the Pump On

**Note the safety information given on pages 6 to 8.**

#### Warning



The pump may only be switched on after it has been completely assembled and with the fan's housing closed.

Operation without intake and exhaust lines, or the silencer not in place is not allowed.

In the exhaust line no pressure +200/-50 mbar must be allowed to build up even if the discharged gas is collected or contained.

Make sure that the gas flow at the exhaust is not blocked or restricted in any way.

Preferably start the ScrewLine with the intake line open, i.e. at atmospheric pressure at its inlet. Under these conditions the run-up current surge will be minimal. The pump will attain its operating temperature about 30 minutes after starting.

#### Caution

Start the pump only six times per hour at the most so as to avoid overloading the motor.

The ScrewLine is equipped between its pump chamber and gear with non-contact seals. These seals are equipped with a vent at the side of the pump. By design, small amounts of gear oil may escape through this vent. This will not adversely affect operation of the pump.

**Caution**

The gear housing is vented in the vicinity of fan wheel through two channels on the side opposite the exhaust. By design, small amounts of gear oil may escape through this vent. This will not adversely affect operation of the pump.

### 2.4.3 Oil Temperature

The temperature of the oil is influenced by the load on the pump, the ambient temperature and the cleanness of the oil cooler.

The temperature of the oil may be measured by the system controller using a standard temperature sensor (Pt 100) or via the SP-Guard. It measures the temperature of the oil downstream of the oil cooler.

If during normal loads and ambient temperatures the temperature of the oil deviates from the process dependent standard levels, the oil cooler should be checked to see if it has accumulated any dirt (see Chapter "Maintenance").

**Caution**

The temperature of the oil should not exceed 70 °C.

### 2.4.4 Regular Checks (Note also Chapter 3 "Maintenance")

Reliable and safe operation is ensured when running the following checks regularly:

- Oil level check
- Check on the oil cooler for accumulated dirt (refer to Chapter 3.2 "Cleaning the Oil Cooler")
- Emptying the condensate separator (optional)
- Check the readings on the SP-Guard (temperatures and vibration levels)
- Clean the inlet screen

A wire-mesh filter is located in the pump's intake port to act as a inlet screen for foreign objects. It should be kept clean at all times in order to avoid a reduction in pumping capacity.

For this purpose, disconnect the intake line, remove the inlet screen from the intake port and clean it in a suitable way. If the inlet screen is defective, replace it.

The cleaning intervals depend on requirements. If large amounts of abrasive materials occur, a suitable dust filter should be fitted into the intake line.

The interval between the regular checks will depend on the ambient conditions and the process in each case and needs to be defined based on experience gained during operation. The temperature of the oil and the dirt accumulated on the oil cooler will have to be checked more frequently when the pump is being operated in a dusty environment. If much condensate is collected, the condensate separator will have to be checked regularly.

## 2.5 Operating Conditions

The ScrewLine should normally be operated continuously. If possible do not switch the pump off for less than one hour. In the case of process interruptions preferably operate the pump with the inlet blocked off, since during operation at ultimate pressure power consumption will be minimal.

**Caution** The pump will have attained its operating temperature about 30 minutes after starting.

Before pumping condensable vapours the ScrewLine should have attained its operating temperature first.

**Caution** Pumping of vapours which will condense when compressed in the pump should be avoided.

If vapours need to be pumped regularly, condensate separators should be fitted in the intake and the exhaust lines. Fitting of an optionally available gas ballast valve is also recommended. The gas ballast valve must be opened (see Chapter 2.9).

If the process is dusty, suitable dust filters must be fitted upstream of the pump.

### Warning



The ScrewLine pump is not suited for pumping of:

- combustible and explosive gas and vapours
- radioactive and toxic substances
- pyrophorous substances
- gas mixtures with an oxygen share of >21 % by volume.

Moreover, the ScrewLine is not suited for installation and operation in explosion hazard areas.

In order to avoid dangerous conditions it needs to be checked before commissioning the pump whether the media which are to be pumped are compatible with the pump.

Backflowing of detrimental gases or gas mixtures from the exhaust line and which form on the side of the system causing dangerous conditions, needs to be reliably prevented.



The highest permissible intake pressure is 1030 mbar.

The ScrewLine may be operated at a pressure at its exhaust flange ranging between 800 mbar (abs.) and 1200 mbar (abs.). Ensure that the gas flow at the exhaust is not blocked or obstructed in any way and that no pressure + 200 / - 50 mbar with respect to atmospheric pressure can occur.

All relevant safety standards and safety regulations must be observed.

After having commissioned the pump and after the pump has been at standstill for a longer period of time, the ScrewLine may generate more noise than usual. This noise is caused by the higher viscosity of the oil at low oil temperatures. As the oil temperature increases the noise level will drop. The increased noise level will not adversely affect the operational reliability of the pump.

**Warning**



**Note**

## 2.6 Switching Off/ Shutting Down

Close the intake line.

Switch the pump off.

In order to drain any condensate, the pump must, if required, be separated by a valve from the process. Please note that process gases and condensate can be dangerous.

**Warning**



The pressure in a pump which has been switched off will increase within a few seconds to the level of the exhaust pressure (normally = ambient pressure). The ScrewLine is not equipped with any means to protect the vacuum. For this reason use, if required, a valve fitted on the intake side which upon standstill of the ScrewLine will automatically seal off the intake port (SECUVAC valve, for example, for this refer to the Leybold full line catalogue, Section C 14, page 29).

In order to prevent damage due to standstill of the pump, a post operation phase of at least 30 minutes with the gas ballast open is recommended after termination of the process, if the process gas contains corrosive, condensable substances or substances which tend to form deposits.

In the case of prolonged standstill times (over three weeks) further measures besides letting the pump run dry need to be introduced for the purpose of avoiding corrosion due to standstill.

For this please contact Leybold for advice.

**Caution**

## 2.7 Emergency Shutdown

The customer himself must ensure that the mains wiring is rated corresponding to the mains voltages and nominal currents. A mains circuit breaker resp. an emergency switch must be so arranged that the supply of mains power is completely interrupted so as to prevent the pump from running up unexpectedly.

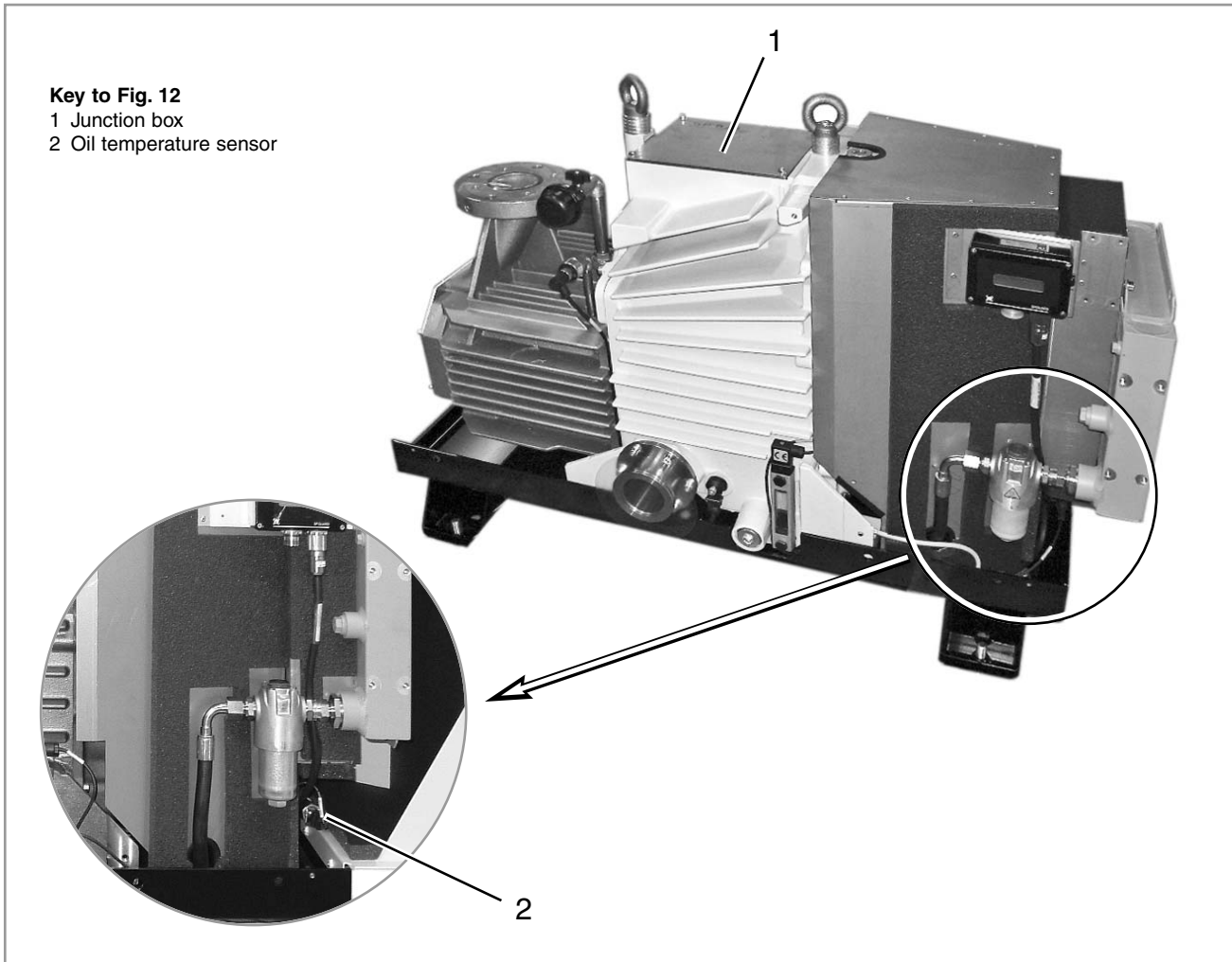

Fig. 12 Sensors at the ScrewLine SP 250 (covers removed)

## 2.8 Pump Monitoring

### 2.8.1 Oil Temperature Sensor Pt 100

For the purpose of monitoring the oil temperature, a temperature sensor (JUMO 902004/10) (12/2) has been installed on the pump.

This oil temperature sensor is of the Pt 100 type in accordance with DIN 60751 Class B and used in a two-wire circuit.

The Pt 100 should be integrated with the plant controller by an electrician so that the ScrewLine pump will automatically be shut down as soon as the max. permissible temperature of 80 °C is exceeded.

#### Caution

If the temperature of the oil deviates during normal loads and ambient conditions from the process dependent standard values, the oil cooler should be checked to see if it has accumulated any dirt (see Chapter Maintenance).

If an optionally available SP-Guard (monitoring system) has been installed on the ScrewLine, then the PT 100 has also been connected and its output is automatically monitored. The PT 100 needs **not** to be connected separately.

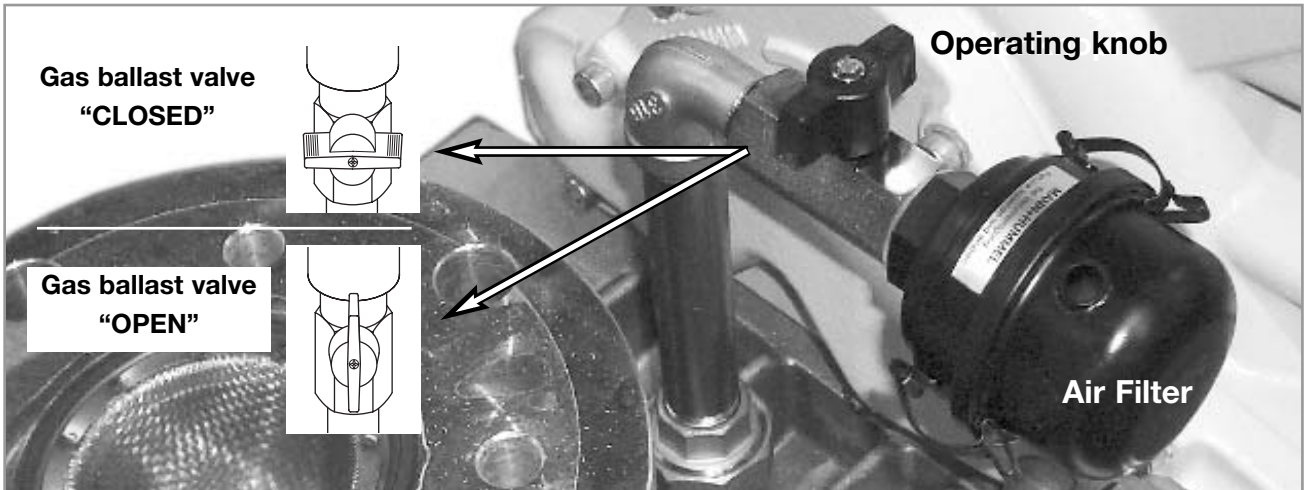

Fig. 13 Manually operated gas ballast valve

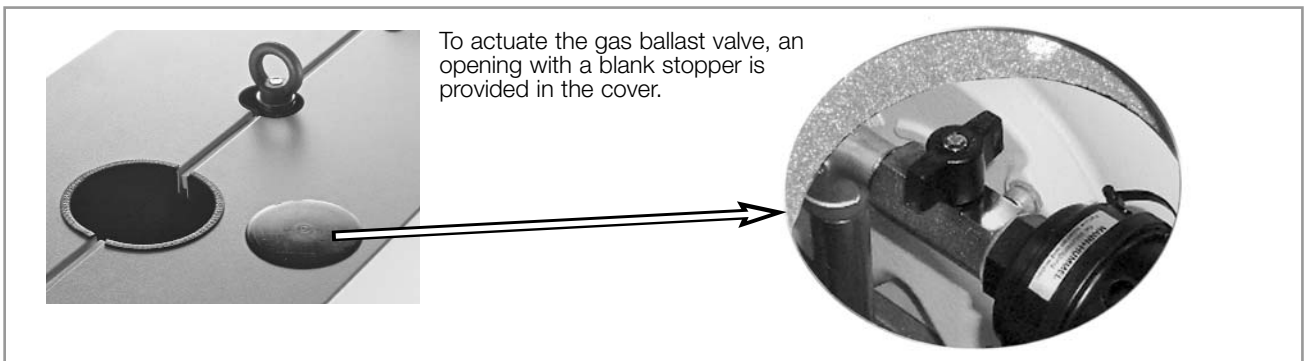

Fig. 13.1 Opening in the cover on the top of the ScrewLine SP 250

## 2.9 Operation with Gas Ballast

When actuating the gas ballast valve please under all circumstances wear gloves since increased temperatures are present within the cover.

### Warning



In case the power supply for the pump fails, a possibly present external gas feed into the ScrewLine from the side of the system must be stopped.

### Note

If the pump is to be shut down, the external gas feed must also be shut off.

The gas ballast valve is used for the purpose of avoiding condensation within the pump. This requires that the ScrewLine has attained its operating temperature

### 2.9.1 Manually Operated Gas Ballast Valve

A 90° turn of the knob will suffice for completely actuating the gas ballast valve, the gas ballast valve is either open or closed (Fig. 13 and 13.1).

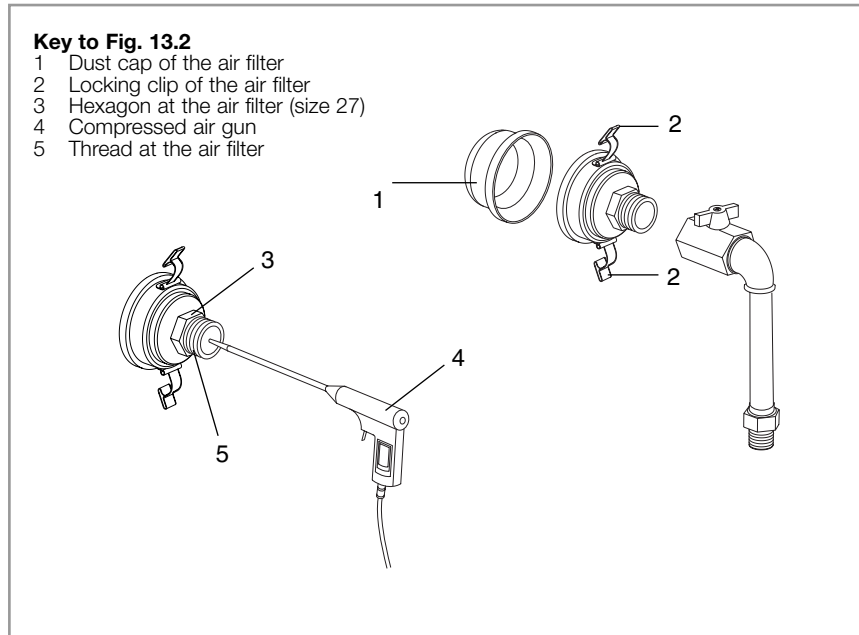

Fig. 13.2 Maintenance of the air filter at the manually operated gas ballast valve

## 2.9.1.1 Maintenance on the Air Filter

The air filter serves the purpose of filtering dust particles out of the air so that only clean air can enter the pump chamber of the ScrewLine.

The air filter should be subjected to maintenance within regular intervals.

For maintenance on the air filter, the cover sections will have to be disassembled (see Section 2.4.1 / Fig. 11).

Open the locking clips at the air filter (13.2/2) and remove the dust cap (13.2/1) from the air filter. Apply an open jaw spanner (size 27) to the hexagon (13.2/3) and unscrew the filter element.

Blow out the filter element from the threaded side with compressed air (13.2/4). Re-seal the thread (13.2/5) with Teflon tape and fit the filter element once more.

### Note

For blowing out the filter, dry compressed air must be used.

### Warning

When blowing out the filter with compressed air, please wear eye protective goggles so as to protect your eyes.



Fit the dust cap again and affix it with the locking clips.

The cover is fitted in the reverse order as described in Chapter 2.4.1.

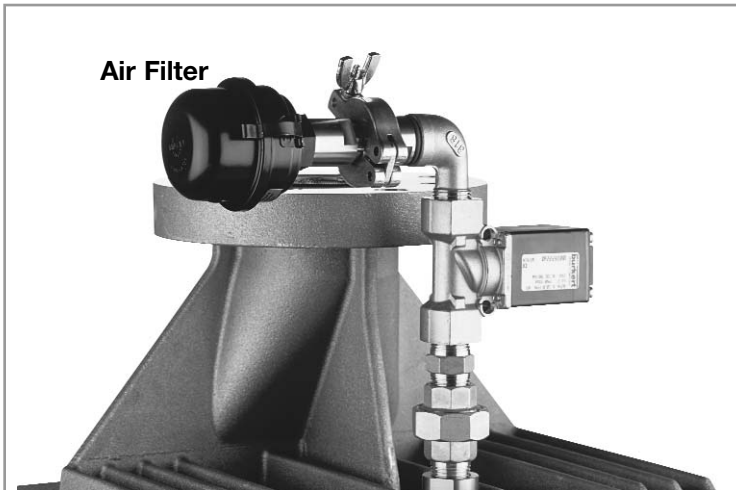

Fig. 14 Solenoid gas ballast valve

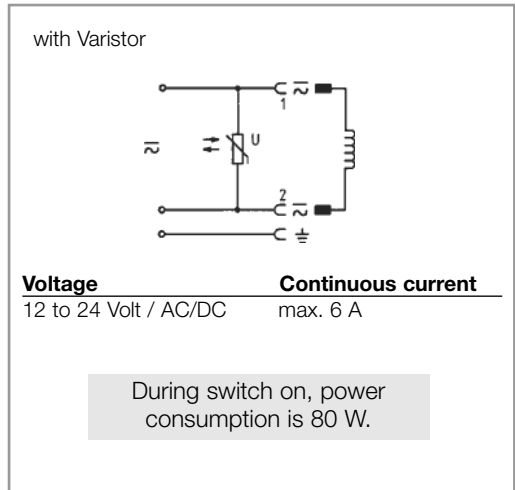

Fig. 14.1 Wiring diagram

- Take the insert with the contacts out of the cap
- Run the cable through the union nut
- Cable connection - see wiring diagram in Fig. 14.1
- Press the insert with the contact back into the cap again
- Tighten the union nut
- Push the gasket onto the electrical connection pins
- Fit the equipment socket right up to its stop
- Secure in place using cylinder head screw M3 x 30

Fig. 14.2 Fitting the equipment socket

### 2.9.2 Solenoid Gas Ballast Valve

The valve is of the normally closed type.

**Note**

In the event of a power supply failure for the pump, a possibly present external gas feed into the ScrewLine must be stopped from the side of the system.

If the pump is to be shut down, the external gas feed must also be shut off.

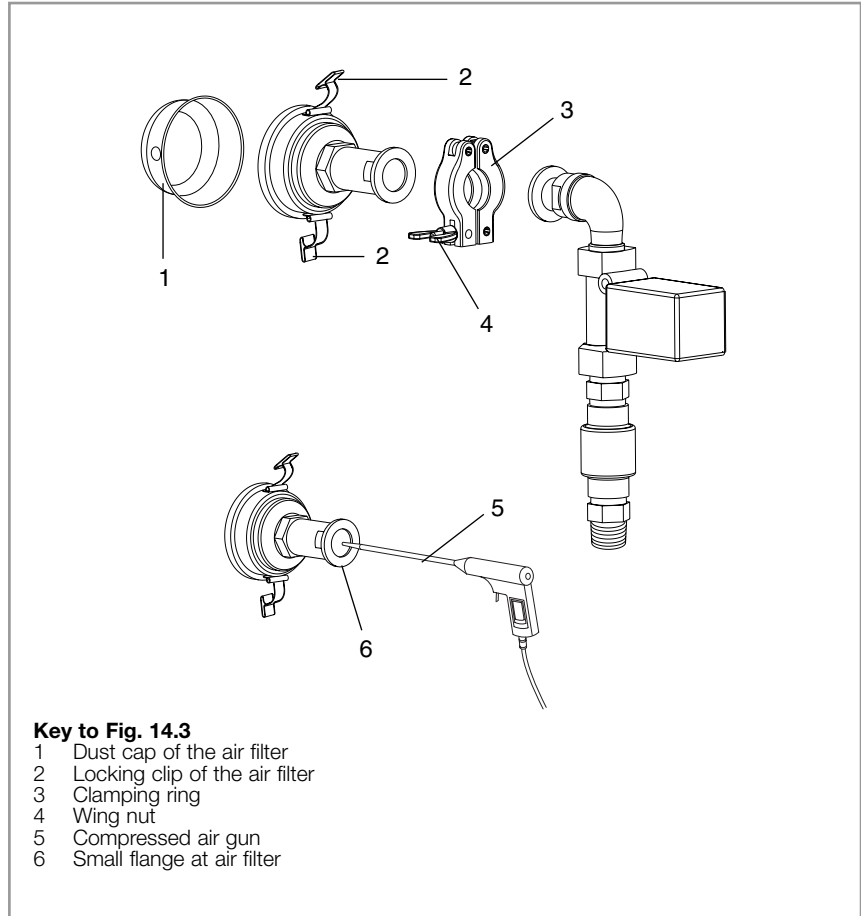

Fig. 14.3 Maintenance of the air filter for the solenoid gas ballast valve

### 2.9.2.1 Maintenance on the Air Filter

The air filter serves the purpose of filtering dust particles out of the air so that only clean air can enter the pump chamber of the ScrewLine.

The air filter should be subjected to maintenance within regular intervals.

For maintenance on the air filter, the cover sections will have to be disassembled (see Section 2.4.1/Fig. 11).

Open the locking clip at the air filter (14.3/2) and remove the dust cap (14.3/1) from the air filter.

Loosen the wing nut (14.3/4) and open the clamping ring (14.3/3) at the air filter, remove the filter element.

Blow out the filter element from the small flange side with compressed air (14.3/5) and fit the filter element again with small flange (14.3/6).

**Note**

For blowing out the filter, dry compressed air must be used.

**Warning**

When blowing out the filter with compressed air, please wear eye protection under all circumstances protective goggles so as to protect your eyes.



Fit the dust cap again and affix it with the locking clips.

The cover is fitted in the reverse order as described in Section 2.4.1.

### 3 Maintenance

During all maintenance and servicing work on the ScrewLine, the pump must be disconnected from all sources of electrical power.

The pump must be reliably prevented from running up inadvertently.

All work within the pump should be left to suitably trained staff. Improper maintenance and repair work will significantly impair the durability or operation of the pump and can result in difficulties when filing warranty claims.

Moreover, it needs to be ensured that no gas can flow backwards through the pump since this might cause the rotors to turn. For this reason vent the vacuum chamber to the level of the exhaust pressure or ensure through suitable valves that vacuum chamber and lines are reliably separated from the pump.

If the pump has been pumping hazardous substances, determine the kind of hazard first and introduce suitable safety measures.

Never operate the pump with its pump chamber open or with the fan's housing removed. There is the risk of suffering injury.

Pressure differences between the inlet and the exhaust can cause an uncontrolled rotation of the pump's shafts thereby presenting a hazard during maintenance work

Note that the surface of the pump can get hot. Under the cover, the surfaces of the ScrewLine may attain temperatures of over 70° C.

If during maintenance work the covers are removed, there is a risk of suffering burns.

Leave the pump to cool down sufficiently or wear suitable protective clothing, gloves and protective goggles.

#### Observe all safety regulations!

When disposing of waste oil and used oil filters observe the applicable environment protection regulations.

Use only original spare parts from Leybold.

#### Ensure that the following maintenance work is done:

(for this also refer to the table in Section 3.6)

- Regularly check the oil cooler to see if it has collected any dirt and clean as required (see Chapter 3.2)
- If a condensate separator is present, empty it regularly.
- If a dust filter is present check it regularly and clean it as required.
- Regularly check the oil level and top up oil as required.
- Oil change and oil filter change (once per year).

#### Warning

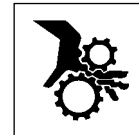

#### Caution

### 3.1 Checking the Oil Level



**Warning**

A warm pump may attain housing and oil temperatures in excess of 70 °C. Let the pump and the oil cool down. Always wear protective gloves and goggles, also to protect yourself against aggressive residues in the oil.

The intervals between the regular checks should be based on the ambient conditions and your experience.

Upon switching the pump on and off, the oil level may fluctuate visibly.

With the pump at **standstill the oil level must be between the maximum and the minimum mark** (see Fig. 10). As soon as the **oil level during operation of the pump drops to the minimum mark** (see Fig. 10), oil must be topped up.

**Note**

When determining the correct oil level at the oil sight glass, the **oil level** itself is decisive and **not the upper edge of the float!**

#### 3.1.1 Oil Change and Oil Filter Change



**Warning**

A warm pump may attain housing and oil temperatures in excess of 70 °C. Let the pump and the oil cool down. Always wear protective gloves and goggles, also to protect yourself against aggressive residues in the oil.

Change the oil while it is still warm and only while the pump is a standstill. Place a sufficiently large collecting vessel (about 10 litres) under the ScrewLine.

**Caution**

When disposing of the waste oil observe the applicable environment protection regulations.

Use only lubricants approved by Leybold.

To change the oil, the cover section on the exhaust side needs to be disassembled (see Chapter 2.4.1/Fig. 11).

Unscrew the oil drain plug (see Fig. 10) and the oil fill plug (see Fig. 10) and drain out the oil.

Clean the sealing surface and firmly screw in the oil drain plug using a gasket which is in perfect condition. Wipe off any oil residues on the housing.

##### 3.1.1.1 Replacing the Oil Filter

Unscrew the fitting (15/2) on the side of the oil cooler. Tilt the oil filter housing outwards by approximately 45° and retighten the fitting. Place a vessel (having a volume of over 1 litre) underneath and unscrew the oil filter housing (15/3), let the oil drain out.

Open the venting screw (15/5) at the oil cooler.

Pull the filter insert out.

Push the new filter insert on until it positively engages.

Replace the O-ring of the filter housing.

Screw the filter housing on up to the stop and tighten.

Screw in the venting screw (15/5) (if required use a new gasket).



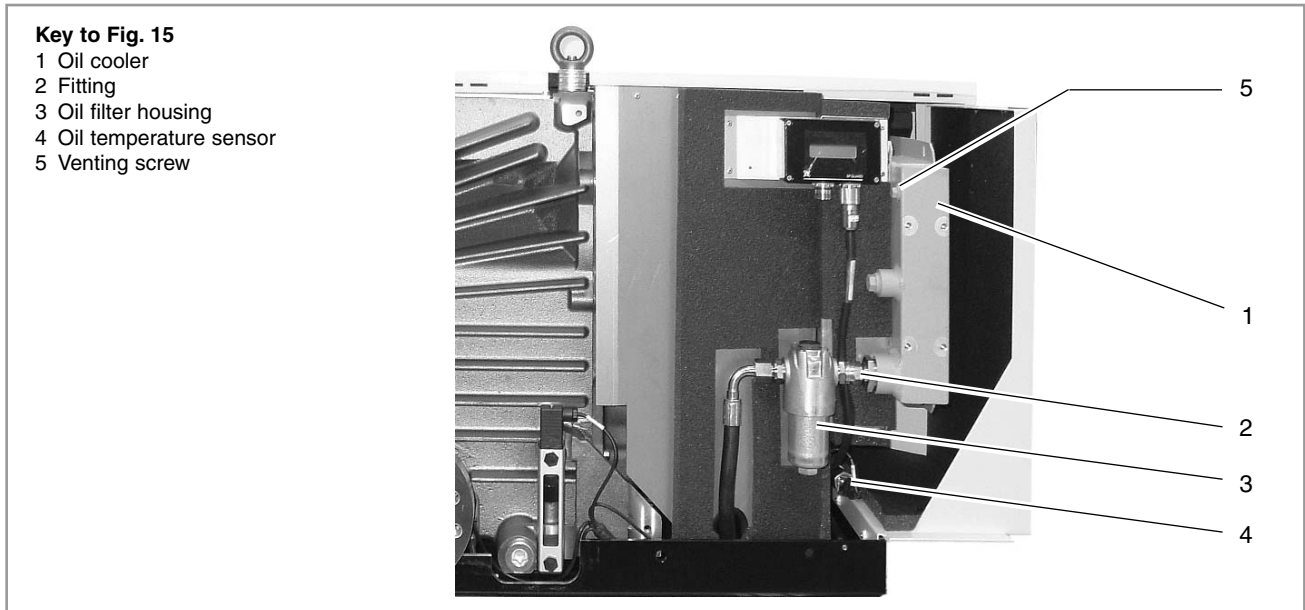

Fig. 15 Replacing the oil filter

Loosen the fitting (15/2) on the side of the oil cooler and turn the filter housing back to its initial position.

Firmly tighten the fitting again.

**Caution**

### 3.1.1.2 Exchanging the Oil

Fill in the fresh gear oil.

When doing so, make sure that the aids used are clean so as to avoid contaminating the oil.

**Caution**

For oil quantity and ordering data for the oil see Chapter 2.4.1.

Clean the oil fill opening and screw in the oil fill plug (Fig. 10) using a gasket which is in perfect condition. Wipe off any oil residues from the housing.

The oil fill opening must be sealed off air-tight.

**Caution**

With the pump at **standstill the oil level must be between the maximum and the minimum mark** (see Fig. 10).

After having exchanged the oil, the cover section on the exhaust side must be fitted once more (see Chapter 2.4.1).

### 3.1.1.3 What to do when too much Oil has been filled in

If too much oil has been filled in, then you should proceed as follows:

1. With the pump at standstill, drain out so much oil that the oil level drops below the maximum mark.
2. Operate the pump for at least one hour.
3. Then visually inspect the rotors and the rotor housing to see if any unwanted oil leaks are present.
4. If required, repeat steps 2 and 4.

**Note** An inspection of the rotor (opening of the pump chamber) must in the case of the ScrewLine only be done by the Leybold Vacuum Field Service.

### 3.2 Cleaning the Oil Cooler



#### Warning

Clean the oil cooler (15/1) only while the pump is at standstill.

Especially protect the pump against being switched on again and separate it from the vacuum system

When blowing out the oil cooler with compressed air, protect your eyes by wearing protective goggles under all circumstances.

#### Caution

Regularly check the oil cooler to see if it has collected any dirt.

The intervals between the regular checks should be made dependent on the ambient conditions and should be defined in accordance with your experience.

For this perform a visual inspection by removing one of the cover sections.

A dirty cooler can cause increased oil and pump temperatures and affect operation and service life of the ScrewLine.

The oil cooler (15/1) can be cleaned with an industrial vacuum cleaner after having removed one of the cover sections.

In the case of highly adhesive dirt at the cooler lamellae, the cooler can be disassembled and cleaned as follows:

- The safety regulations given in Chapter 3 need to be observed
- Remove both side covers
- Disassemble the rear panel
- At the cooler remove the 4 mounting screws
- Fold and the cooler down onto a suitable rest
- Clean the cooler with compressed air, (wear protective goggles)

#### Caution

Please make sure that the lamellae are not damaged.

Installation is performed in the reverse order.

### 3.3 Draining Out Condensate (optional)

To drain the condensate out, the pump will have to be separated from the process by a valve. Please note that process gases and condensate may present a hazard to health.

#### Warning



The optional silencer (P/N 119 002) has a condensate drain. Possibly present liquid which has collected in the silencer can be drained out through the condensate drain.

The silencer must be checked regularly especially if much condensate is collected.

The interval between the regular checks will depend on the ambient conditions and the process in each case and needs to be defined based on experience gained during operation.

Empty the condensate separator.

### 3.4 Cleaning the Dust Filter (optional)

The dust filters which are installed upstream of the ScrewLine need to be checked regularly for contamination and cleaned as required.

### 3.5 Leybold Service

If you send a pump to Leybold indicate whether the pump is free of substances damaging to health or whether it is contaminated. If it is contaminated also indicate the nature of hazard.

To do so, you must use a preprinted form which we shall send to you upon request.

A copy of this form is reproduced at the end of these Operating Instructions: "Declaration of Contamination of Compressors, Vacuum Pumps and Components". Moreover, you may download a suitable form from the Internet: [www.leybold.com](http://www.leybold.com) under the headline "Support and Downloads".

Please attach this form to the pump or enclose it with the pump.

This "Declaration of Contamination" is required to meet the requirements of German Law and to protect our personnel.

Leybold must return any pumps without a "Declaration of Contamination" to the sender's address.

Before packaging (respectively shipping) the pump it should, if possible be purged with inert gas, but as a minimum requirement it should be emptied of all pumped substances.

This possibly also includes all parts which belong to the pump system, like coolers, vessels etc.

**Warning**



**Note**

The pump must be packed in such a way, that it will not be damaged during shipping and so that any contaminants are not released from the package.

Before transporting the pump, drain out the oil under all circumstances!

For transporting, the pump has been fitted on to a special pallet, please retain this pallet in case the pump needs to be returned.

**3.6 Table / Maintenance and Servicing Work ScrewLine SP 250**

Maintenance and Servicing Work on the ScrewLine SP 250		Model	Periodical/lt required	Annually	Every 2 years	40,000 h or every 5 years <sup>1)</sup>	Carried out by	Where to do	Spare parts	Remarks
<b>Exhaust silencer</b> , check, empty	Access.	●					Operator	On site	85	See Operating Instructions exhaust silencer
<b>Dust filter</b> , check, clean, empty	Access.	●					Operator	On site		See Operating Instructions dust filter
<b>Non-return valve</b> , do a function test, clean, replace O-rings	Access.	●					Operator	On site	EK 110000828	See Operating Instructions non-return valve
<b>Ruvac adapter</b> , replace O-rings, replace inlet screen (elastic parts)	Access.	●					Operator	On site	EK 110000835 (EK 1100002677)	See Operating Instructions Ruvac adapter (replace elastic parts only if defective)
<b>Purge gasket</b> , function test, replace purge gas connection	Access.		●				Operator	On site	EK 110000834	See Operating Instructions purge gas kit
<b>Gas ballast facility</b> , cleaning filter	SP 250	●					Operator	On site		See Operating Instructions ScrewLine SP 250
<b>Oil cooler</b> , check, clean	SP 250	●					Operator	On site		See Operating Instructions ScrewLine SP 250
<b>Oil level</b> , check	SP 250	●					Operator	On site		See Operating Instructions ScrewLine SP 250
<b>Oil change and oil filter change</b> ,	SP 250		●				Operator or Leybold service	On site	EK 1100000820 (EK 1100000837)	See Operating Instructions ScrewLine SP 250 (no gear or oil is included in EK 110000837)
<b>Inspection of the screw rotors and the pump housing</b>	SP 250	●					Leybold service	On site	EK 1100000821	Rotor inspections can only be done by the authorised after sales service
<b>Full service</b>	SP 250						Leybold-Service	Authorised service centre <sup>2)</sup>		Full service can only be done at authorised Leybold service centres

<sup>1)</sup> depending on which applies first

<sup>2)</sup> see service addresses

# 4 Troubleshooting

Malfunction	Possible cause	Remedy	Repair
Pump does not start up.	Defective wiring.	Check the wiring and have it repaired.	Electrician
	Motor protection switch not set up properly (applies only to three-phase motors) Supply voltage does not match the motor's rating Motor defective.	Properly set up the motor protection switch.	Electrician
Pump does not attain its ultimate pressure	Pump seized. Links in the motors junction box.	Have the pump repaired. Set the links as detailed in the wiring diagram.	Service Service Electrician
	Method of measurem. or meas. equipment is unsuitable.	Use correct method of measurem. and meas.instrument. Measure the pressure directly at the pump's intake flange.	-
Pumping speed of the pump is too low	External leak. Degassing due to water residues.	Have the pump repaired. Operate the pump for at least 30 minutes with gas ballast on, check the process.	Service
	Pump much contaminated by the process. Dirt in the exhaust line.	Disassemble and clean the pump. Clean the exhaust line and then operate the pump with gas ballast on.	Service Service
	<b>Caution</b> If oil-sealed pumps were used before, please only use cleaned and oil-free pipes. Exhaust pressure too high (max. + 200 mbar above ambient pressure). Pump's temperature is too low.	Optimise the cross-section of the exhaust line (if required clean the exhaust line). Let the pump run warm (> 1h).	
	Inlet screen in the intake port is clogged. Connecting lines too narrow or too long.	Clean the inlet screen. Install sufficiently wide lines which are as short as possible. <b>Precaution:</b> install a dust filter in the intake line. Replace the filter element.	
After switching the pump off under vacuum, the pressure in the system increases too fast.	Exhaust back pressure too high. Nominal pumping speed too low.	Optimise the cross-section of the exhaust line. Check the application.	
	Leak in the system. No valve for blocking the inlet (anti-suckback valve) has been fitted which closes automatically upon pump standstill Valves at the intake are not closed.	Check the system. Fit a valve to block the intake line. Close the valve at the intake port.	
Pump gets hotter than previously observed.	The flow of cooling air is obstructed. Ambient temperature is too high. Process gas is too hot.	Correctly install the pump. Correctly install the pump (< 40 °C) Change the process, cool as required.	
	Deviating nominal supply voltage. Exhaust pressure is too high. Oil cooler has accumulated dirt,	Check motor rating and mains voltage. Optimise the cross-section of the exhaust line. Clean the oil cooler with compressed air.	Electrician
The pump is extremely loud.	Bearing damage. Thick particle deposits.	Have the pump repaired. Clean the pump, respectively run maintenance.	Service Service
	Defective silencer. High gas of throughput with open exhaust line, without silencer.	Have the silencer repaired. Install an exhaust line or a silencer.	
Oil film in the junction box.	Oil ingress after longer periods of utilisation,	No action is required.	

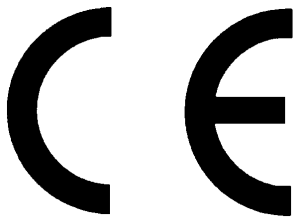

# EC-Declaration of Conformity

We - LEYBOLD Vacuum GmbH - here with declare that the products defined below meet the basic requirements regarding safety and health of the relevant EC directives by design, type and versions which are brought into circulation by us.

In case of any product changes made without our approval, this declaration will be void.

Compliance with the EMC guideline requires that the components be installed within the system or machine in a manner adapted to EMC requirements.

Designation of the products:     **Dry compressing screw vacuum pump**  
Type:                                 **ScrewLine SP 250**  
P/N:                                 **115 001, 115 002, 115 003, 115 004, 115 005**

## The products conform to the following directives:

- EC Directive on Machinery (98/37/EG) and (98/79/EG)
- EC Directive on Low-Voltages 73/23/EWG and 93/68/EG
- EC EMC Directive 89/336/EWG, 91/263/EWG, 92/31/EWG and 93/68/EWG.

## Applied harmonised standards:

- EN 1012-2, 1996             ■ EN 61010 - 1, 2001
- EN 60204-1, 1997         ■ EN 61326, 1997
- EN 60034/A11, 2002

Cologne November 14, 2005



---

Dr. Ulrich Jung  
Head of Technology Development

Cologne November 14, 2005

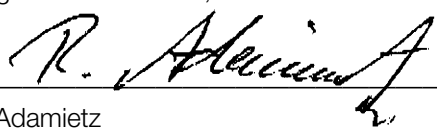

---

Ralf Adamietz  
Head of Design

**Leybold Vacuum GmbH**  
Bonner Straße 498  
D-50968 Cologne  
Tel.:     ++49 (0)221 347-0  
Fax:     ++49 (0)221 347-1250  
documentation@leybold.com

[www.leybold.com](http://www.leybold.com)

## Declaration of Contamination of Compressors, Vacuum Pumps and Components

The repair and / or servicing of compressors, vacuum pumps and components will be carried out only if a correctly completed declaration has been submitted. **Non-completion will result in delay.** The manufacturer can refuse to accept any equipment without a declaration.

**A separate declaration has to be completed for every single component.**

This declaration may be completed and signed only by authorised and qualified staff.

Customer/Dep./Institute: _____ Address _____ Person to contact: _____ Phone: _____ Fax: _____ Order number of customer: _____	<b>Reason for returning</b> <input checked="" type="checkbox"/> applicable please mark <input type="checkbox"/> repair <input type="checkbox"/> chargeable <input type="checkbox"/> warranty <input type="checkbox"/> replacement <input type="checkbox"/> chargeable <input type="checkbox"/> warranty <input type="checkbox"/> DKD-calibration <input type="checkbox"/> Factory calibration <b>restoring goods because of following reason:</b> <input type="checkbox"/> rent/loan <input type="checkbox"/> for credit <input type="checkbox"/> against exchange <input type="checkbox"/> exchange already received/arranged
---	--

<b>A. Description of the equipment (machine or component)</b>	Ancillary equipment
Type: _____	_____
Part number: _____	_____
Serial number: _____	_____
Type of oil used: _____	_____

<b>B. Condition of the equipment</b>					
	No	Yes	No		
1. Has the equipment been used	<input type="checkbox"/>	<input type="checkbox"/>	<input type="checkbox"/>	<b>Contamination:</b>	
2. Drained (Product/service fluid)	<input type="checkbox"/>	<input type="checkbox"/>	<input type="checkbox"/>	toxic	<input type="checkbox"/> No <input type="checkbox"/> Yes
3. All openings sealed airtight	<input type="checkbox"/>	<input type="checkbox"/>	<input type="checkbox"/>	corrosive	<input type="checkbox"/> No <input type="checkbox"/> Yes
4. Purged	<input type="checkbox"/>	<input type="checkbox"/>	<input type="checkbox"/>	microbiological	<input type="checkbox"/> No <input type="checkbox"/> Yes
If yes which cleaning agent:	_____			explosive	<input type="checkbox"/> No <input type="checkbox"/> Yes
and which method of cleaning:	_____			radioactive	<input type="checkbox"/> No <input type="checkbox"/> Yes
				other harmful substances	<input type="checkbox"/> No <input type="checkbox"/> Yes

<b>C. Description of processed substances (Please fill in absolutely)</b>	
1. What substances have come into contact with the equipment: Trade name and / or chemical term of service fluids and substances processed, properties of the substances; According to safety data sheet (e.g. toxic, inflammable, corrosive, radioactive)	
Trade name:	Chemical name:
a) _____	Residues: <input type="checkbox"/> Yes <input type="checkbox"/> No
b) _____	<input type="checkbox"/> Yes <input type="checkbox"/> No
c) _____	<input type="checkbox"/> Yes <input type="checkbox"/> No
d) _____	<input type="checkbox"/> Yes <input type="checkbox"/> No
2. Are these substances harmful?	Yes <input type="checkbox"/> No <input type="checkbox"/>
3. Dangerous decomposition products when thermally loaded	<input type="checkbox"/> Yes <input type="checkbox"/> No
Which: _____	

**Components contaminated by microbiological, explosive or radioactive products will not be accepted without written evidence of decontamination.**

### D. Legally binding declaration

**I / we hereby declare that the information supplied on this form is accurate and sufficient to judge any contamination level.**

Name of authorised person (block letters): \_\_\_\_\_

Date \_\_\_\_\_ Signature of authorised person \_\_\_\_\_

Company stamp





# Sales and Service Net Worldwide

## Germany

**Leybold Vacuum GmbH**  
Bonner Strasse 498  
D-50968 Cologne  
Phone: +49-221-347 1234  
Fax: +49-221-347 1245  
sales@leybold.com

**Leybold Vacuum GmbH**  
**Sales Area North/East**  
Branch office Berlin  
Buschkruhgallee 33  
1. Obergeschoss  
D-12359 Berlin  
Phone: +49-30-435 609 0  
Fax: +49-30-435 609 10  
sales.berlin@leybold.com

**Leybold Vacuum GmbH**  
**Sales Area South/Southwest**  
Branch office Munich  
Karl-Hammerschmidt-Strasse 38  
D-85609 Aschheim/Dornach  
Phone: +49-89-357 33 90  
Fax: +49-89-357 33 933  
sales.muenchen@leybold.com  
service.muenchen@leybold.com

**Leybold Vacuum GmbH**  
**Sales Area West**  
Branch office Cologne  
Emil-Hoffmann-Straße 43  
D-50996 Cologne-Suerth  
Phone: +49-221-347 1270  
Fax: +49-221-347 1291  
sales.koeln@leybold.com

**Leybold Vacuum GmbH**  
**Service Center**  
Emil-Hoffmann-Straße 43  
D-50996 Cologne-Suerth  
Phone: +49-221-347 1439  
Fax: +49-221-347 1945  
service@leybold.com

**Leybold Vacuum GmbH**  
**Mobile after sales service**  
Emil-Hoffmann-Straße 43  
D-50996 Cologne-Suerth  
Phone: +49-221-347 1765  
Fax: +49-221-347 1944  
kundendienst@leybold.com

**Leybold Vacuum**  
**Dresden GmbH**  
Zur Wetterwarte 50, Haus 304  
D-01109 Dresden  
Service:  
Phone: +49-351-88 55 00  
Fax: +49-351-88 55 041  
info@leybold-dresden.de  
www.leybold-dresden.de

## Hotline

**Sales: +49-221-347 1234**

**Service: +49-221-347 1765**

sales@leybold.com  
service@leybold.com

## Europe

Belgium  
**Leybold Vacuum Nederland B.V.**  
**Belgisch bijkantoor**  
Leuvensesteenweg 542-9A  
B-1930 Zaventem  
Sales:  
Phone: +32-2-711 00 83  
Fax: +32-2-720 83 38  
sales.belgium@leybold.com  
Service:  
Phone: +32-2-711 00 82  
Fax: +32-2-720 83 38  
service.belgium@leybold.com

France  
**Leybold Vacuum France S.A.**  
7, Avenue du Québec  
Z.A. de Courtaboef, B.P. 42  
F-91942 Courtaboef Cedex  
Sales and Service:  
Phone: +33-1-69 82 48 00  
Fax: +33-1-69 07 57 38  
sales.france@leybold.com

**Leybold Vacuum France S.A.**  
**Valence Factory**  
640, Rue A. Bergès - B.P. 107  
F-26501 Bourg-lès-Valence Cedex  
Phone: +33-4-75 82 33 00  
Fax: +33-4-75 82 92 69  
marketing.valence@leybold.fr

Great Britain  
**Leybold Vacuum UK Ltd.**  
Waterside Way, Plough Lane  
GB-London SW17 0HB  
Sales:  
Phone: +44-20-8971 7000  
Fax: +44-20-8971 7001  
sales@leybold.com  
Service:  
Phone: +44-20-8971 7030  
Fax: +44-20-8971 7003  
service@leybold.com

Italy  
**Leybold Vacuum Italia S.p.A.**  
8, Via Trasimeno  
I-20128 Milano  
Sales:  
Phone: +39-02-27 22 31  
Fax: +39-02-27 20 96 41  
sales@leybold.it  
Service:  
Phone: +39-02-27 22 31  
Fax: +39-02-27 20 96 41  
service@leybold.it

Field Service Base  
Z.I.Le Capanne  
I-05021 Acquasparta (TR)  
Phone: +39-0744-93 03 93  
Fax: +39-0744-94 42 87  
service@leybold.it

Netherlands  
**Leybold Vacuum Nederland B.V.**  
Computerweg 7  
NL-3542 DP Utrecht  
Sales and Service:  
Phone: +31-346-58 39 99  
Fax: +31-346-58 39 90  
sales.netherlands@leybold.com  
service.netherlands@leybold.com

Spain  
**Leybold Vacuum España S.A.**  
C/. Huelva, 7  
E-08940 Cornellà de Llobregat  
(Barcelona)  
Sales:  
Phone: +34-93-666 46 16  
Fax: +34-93-666 43 70  
sales.spain@leybold.com  
Service:  
Phone: +34-93-666 49 51  
Fax: +34-93-685 40 10

Sweden  
**Leybold Vacuum Scandinavia AB**  
Box 9084  
SE-40092 Göteborg  
Sales and Service:  
Phone: +46-31-68 84 70  
Fax: +46-31-68 39 39  
info@leybold.se  
Visiting/delivery address:  
Datavägen 57B  
SE-43632 Askim

Switzerland  
**Leybold Vacuum Schweiz AG**  
Leutschenbachstrasse 55  
CH-8050 Zürich  
Sales:  
Phone: +41-1-308 40 50  
Fax: +41-1-302 43 73  
sales@leybold.ch  
Service:  
Phone: +41-1-308 40 62  
Fax: +41-1-308 40 60

## America

USA  
**Leybold Vacuum USA Inc.**  
5700 Mellon Road  
Export, PA 15632  
info@leyboldvacuum.com  
Sales:  
Eastern & Central time zones  
Phone: +1-724-327-5700  
Fax: +1-724-733-1217  
Pacific, Mountain,  
Alaskan & Hawaiian time zones  
Phone: +1-480-752-9191  
Fax: +1-480-752-9494  
Service:  
Phone: +1-724-327-5700  
Fax: +1-724-733-3799

## Asia

P.R. China  
**Leybold Vacuum (Tianjin)**  
**International Trade Co., Ltd.**  
Beichen Economic  
Development Area (BEDA),  
No. 8 Western Shuangchen Road  
Tianjin 300400, China  
Sales and Service:  
Phone: +86-22-2697 0808  
Fax: +86-22-2697 4061  
Fax: +86-22-2697 2017  
leybold@leybold.com.cn

**Leybold Vacuum (Tianjin)**  
**Equipment Manufacturing Co., Ltd.**  
Beichen Economic  
Development Area (BEDA),  
No. 8 Western Shuangchen Road  
Tianjin 300400, China  
Phone: +86-22-2697 0808  
Fax: +86-22-2697 4061  
Fax: +86-22-2697 2017  
leybold@leybold.com.cn

**Leybold Vacuum (Tianjin)**  
**International Trade Co., Ltd.**  
Beijing Branch:  
1-908, Beijing Landmark Towers  
8 North Dongsanhuan Road  
Chaoyang District  
Beijing 100004, China  
Sales and Service:  
Phone: +86-10-6590-7607  
Fax: +86-10-6590-7622

**Leybold Vacuum (Tianjin)**  
**International Trade Co., Ltd.**  
Shanghai Branch:  
Add: No. 33, 76 Futedong San  
Rd., Waigaoqiao FTZ.,  
Shanghai 200131, China  
Sales and Service:  
Phone: +86-21-5064-4666  
Fax: +86-21-5064-4668  
leybold\_sh@leybold.com.cn

**Leybold Vacuum (Tianjin)**  
Guangzhou Branch:  
Add: G/F,#301 Building,  
110 Dongguangzhuang Rd.  
Tianhe District,  
Guangzhou 510610, China  
Sales:  
Phone: +86-20-8723-7873  
Phone: +86-20-8723-7597  
Fax: +86-20-8723-7875  
leybold\_gz@leybold.com.cn

India  
**Leybold Vacuum India Pvt Ltd.**  
A-215 Road No. 30  
MIDC Wagle Industrial Estate  
Thane(W) - 400 604 Maharashtra  
India  
Sales and Service:  
Phone: +91-22-2581 2929  
Fax: +91-22-2581 2626  
ivt2004@yahoo.com

Japan  
**Leybold Vacuum**  
**Japan Co., Ltd.**  
Head Office  
Tobu A.K. Bldg. 4th Floor  
23-3, Shin-Yokohama  
3-chome  
Kohoku-ku, Yokohama-shi  
Kanagawa-ken 222-0033  
Sales:  
Phone: +81-45-4713330  
Fax: +81-45-4713323

**Leybold Vacuum**  
**Japan Co., Ltd.**  
Osaka Branch Office  
MURATA Bldg. 7F  
2-7-53, Nihi-Miyahara  
Yodogawa-ku  
Osaka-shi 532-0004  
Phone: +81-6-6393-5211  
Fax: +81-6-6393-5215

**Leybold Vacuum**  
**Japan Co., Ltd.**  
Tsukuba Technical S.C.  
Tsukuba Minami Daiichi  
Kogyo Danchi  
21, Kasumi-no-Sato,  
Ami-machi, Inashiki-gun  
Ibaraki-ken, 300-0315  
Service:  
Phone: +81-298-89-2841  
Fax: +81-298-89-2838

Korea  
**Leybold Vacuum Korea Ltd.**  
#761-4, Yulkeum-ri,  
SungHwan-eup, Cheonan-City  
Choongchung-Namdo,  
330-807, Korea  
Sales:  
Phone: +82-41-580-4420  
Fax: +82-41-588-3737  
Service:  
Phone: +82-41-580-4415  
Fax: +82-41-588-3737

Singapore  
**Leybold Vacuum**  
**Singapore Pte Ltd.**  
No.1, International  
Business Park,  
B1-20B, The Synergy  
Singapore 609917  
Sales and Service:  
Phone: +65-66652910  
Fax: +65-66668202  
vacuum@leyboldvac.com.sg

Taiwan  
**Leybold Vacuum Taiwan Ltd.**  
No 416-1, Sec. 3  
Chung-Hsin Rd., Chu-Tung  
Hsin-Chu, Taiwan, R.O.C.  
Sales and Service:  
Phone: +886-3-5833988  
Fax: +886-3-5833999

**Leybold Vacuum Products Inc.**  
5700 Mellon Road  
Export, PA. 15632-8900  
Phone: 724-327-5700  
Fax: 724-325-5777  
info@leyboldvacuum.com

**Leybold Vacuum GmbH**  
Bonner Strasse 498  
D-50968 Cologne  
Phone: +49-221 347-0  
Fax: +49-221 347-1250  
info@leybold.com

**Leybold**  
vacuum

www.leybold.com